

VEGABAR 54

4 ... 20 mA/HART

Pressure transmitter with MINI-CERTEC® measuring cell



Application area

VEGABAR 54 is a pressure transmitter for use in the paper, food processing and pharmaceutical industries as well as in water/sewage water plants. Depending on the version, it is used for level, gauge, absolute pressure or vacuum measurement. Measured products are gases, vapours and liquids, also those containing abrasive substances.

Advantages

- Dry, ceramic-capacitive sensor element
- High abrasion and overload resistance
- High accuracy

Function

The sensor element is the CERTEC® measuring cell with flush, abrasion resistant ceramic diaphragm. The hydrostatic pressure of the medium or the process pressure causes a capacitance change in the measuring cell via the diaphragm. This change is converted into an appropriate output signal and outputted as measured value.

The CERTEC® measuring cell is also equipped with a temperature sensor. The temperature value can be displayed via the indicating and adjustment module or processed via the signal output.

Technical data

Measuring ranges	1 ... 72 bar (-14.5 ... 1044 psig)
Smallest measuring range	0.1 bar (1.45 psig)
Deviation	< 0.2 %, optionally < 0.1 %
Process fitting	Thread from ½", flanges from DN 25, fittings for the food processing and paper industry
Process temperature	-40 ... +120 °C (-40 ... +248 °F)
Ambient, storage and transport temperature	-40 ... +80 °C (-40 ... +176 °F)
Operating voltage	12 ... 36 V DC

Materials

The wetted parts of the instrument are made of 316L, PVDF or sapphire-ceramic®. The process seal is available in FKM, FFKM as well as EPDM. You can find a complete overview of the available materials and seals in the "configurator" on our homepage at www.vega.com/configurator.

Housing versions

The housings are available as single chamber or double chamber version in plastic, stainless steel or aluminium.

They are available in protection ratings up to IP 68 (25 bar) with external electronics.

Electronics versions

The instruments are available in different electronics versions. Apart from the two-wire electronics with 4 ... 20 mA or 4 ... 20 mA/HART, two purely digital versions with Profibus PA and Foundation Fieldbus are available.

Approvals

The instruments are suitable for use in hazardous areas and are approved e.g. according to ATEX and IEC. The instruments have also different ship approvals such as e.g. GL, LRS or ABS.

You can find detailed information on the existing approvals in the "configurator" on our homepage under www.vega.com/configurator.

Operation

The adjustment of the instrument is carried out via the optional indicating and adjustment module PLICSCOM or via a PC with the adjustment software PACTware and respective DTM. Further adjustment options are available via HART communicator as well as manufacturer-specific programs such as AMS™ or PDM.

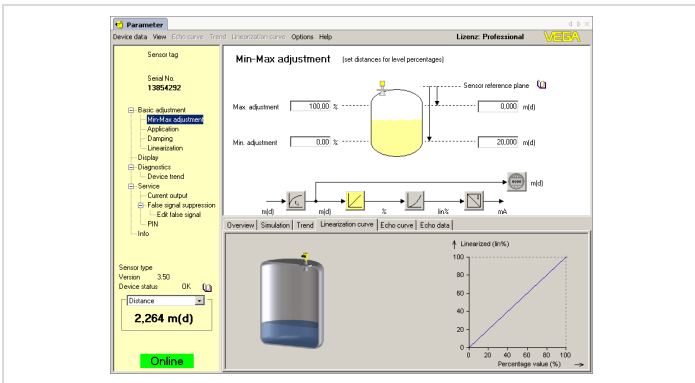

Electrical connection

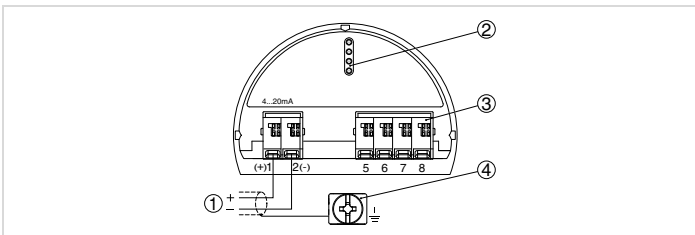

Electronics and connection compartment, single chamber housing

- 1 Voltage supply/Signal output
- 2 For indicating and adjustment module or interface adapter
- 3 For external indicating and adjustment unit
- 4 Ground terminal for connection of the cable screen

You can find details on the electrical connection in the operating instructions of the instruments on our homepage under www.vega.com/downloads.

Dimensions

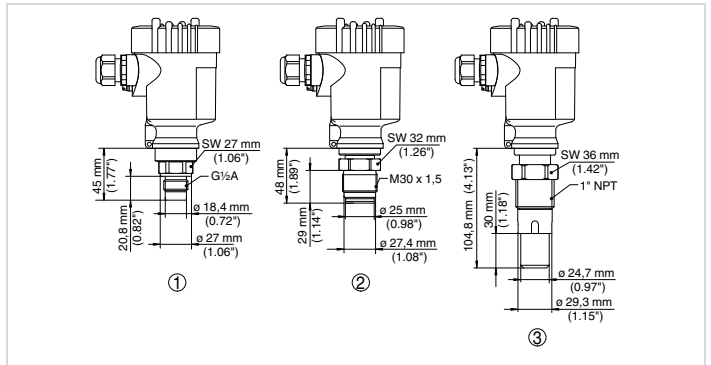

Dimensions VEGABAR 54

- 1 Threaded version G $\frac{3}{4}$ A, manometer connection EN 837
- 2 Threaded version G1 A, absolutely front-flush
- 3 Threaded version 1" suitable for PASVE

Information

You can find further information about the VEGA product line on our homepage www.vega.com. In the download section under www.vega.com/downloads you'll find free operating instructions, product information, brochures, approval documents, instrument drawings and much, much more. There, you will also find GSD and EDD files for Profibus PA systems as well as DD and CFF files for Foundation Fieldbus systems.

Device selection

With the "finder" you can select the measuring principle best suiting your application: www.vega.com/finder. You can find detailed information on the instrument versions in the "configurator" on our homepage under www.vega.com/configurator.

Contact

You can find the VEGA agency serving your area on our homepage www.vega.com.