

Operating Instructions VEGADIS 11



Indication
and adjustment



Content

1	About this document	
1.1	Function	4
1.2	Target group	4
1.3	Symbolism used	4
2	For your safety	
2.1	Authorised personnel	5
2.2	Appropriate use.	5
2.3	Warning about misuse	5
2.4	General safety instructions.	5
2.5	Safety approval markings and safety tips	5
2.6	CE conformity	5
2.7	Safety instructions for Ex areas	6
2.8	Environmental instructions	6
3	Product description	
3.1	Configuration.	7
3.2	Principle of operation.	7
3.3	Operation	8
3.4	Packaging, transport and storage	8
4	Mounting	
4.1	General instructions.	9
4.2	Mounting instructions.	9
5	Connecting to power supply	
5.1	Preparing the connection	10
5.2	Connection procedure	10
5.3	Wiring plan	11
6	Set up	
6.1	Adjustment system	13
6.2	Indication scaling.	13
7	Maintenance and fault rectification	
7.1	Maintenance	16
7.2	Remove interferences	16
7.3	Instrument repair	17
8	Dismounting	
8.1	Dismounting steps	18
8.2	Disposal	18

9 Supplement

9.1 Technical data. 19
9.2 Dimensions. 20

1 About this document

1.1 Function

This operating instructions manual provides all the information you need for mounting, connection and setup as well as important instructions for maintenance and fault rectification. Please read this information before putting the instrument into operation and keep this manual accessible in the immediate vicinity of the device.

1.2 Target group

This operating instructions manual is directed to trained personnel. The contents of this manual should be made available to these personnel and put into practice by them.

1.3 Symbolism used



Information, tip, note

This symbol indicates helpful additional information.



Caution: If this warning is ignored, faults or malfunctions can result.

Warning: If this warning is ignored, injury to persons and/or serious damage to the instrument can result.

Danger: If this warning is ignored, serious injury to persons and/or destruction of the instrument can result.



Ex applications

This symbol indicates special instructions for Ex applications.



List

The dot set in front indicates a list with no implied sequence.



Action

This arrow indicates a single action.



Sequence

Numbers set in front indicate successive steps in a procedure.

2 For your safety

2.1 Authorised personnel

All operations described in this operating instructions manual must be carried out only by trained specialist personnel authorised by the operator.

During work on and with the device the required personal protection equipment must always be worn.

2.2 Appropriate use

VEGADIS 11 is a digital indicating instrument for 4 ... 20 mA circuits.

2.3 Warning about misuse

Inappropriate or incorrect use of the instrument can give rise to application-specific hazards, e.g. vessel overflow or damage to system components through incorrect mounting or adjustment.

2.4 General safety instructions

This is a high-tech instrument requiring the strict observance of standard regulations and guidelines. The user must take note of the safety instructions in this operating instructions manual, the country-specific installation standards as well as all prevailing safety regulations and accident prevention rules.

The instrument must only be operated in a technically flawless and reliable condition. The operator is responsible for trouble-free operation of the instrument.

During the entire duration of use, the user is obliged to determine the compliance of the required occupational safety measures with the current valid rules and regulations and also take note of new regulations.

2.5 Safety approval markings and safety tips

The safety approval markings and safety tips on the device must be observed.

2.6 CE conformity

VEGADIS 11 is in CE conformity with EMC (89/336/EWG) and LVD (73/23/EWG) and fulfills NAMUR recommendation NE 21.

Conformity has been judged according to the following standards:

- EMC:
 - Emission EN 50081-1
 - Susceptibility EN 50082-2
- LVD: EN 61010-1

2.7 Safety instructions for Ex areas

Please note the Ex-specific safety information for installation and operation in Ex areas. These safety instructions are part of the operating instructions manual and come with the Ex-approved instruments.

2.8 Environmental instructions

Protection of the environment is one of our most important duties. That is why we have introduced an environment management system with the goal of continuously improving company environmental protection. The environment management system is certified according to DIN EN ISO 14001.

Please help us fulfil this obligation by observing the environmental instructions in this manual:

- Chapter "*Packaging, transport and storage*"
- Chapter "*Disposal*"

3 Product description

3.1 Configuration

Scope of delivery

The scope of delivery encompasses:

- Digital indicating instrument VEGADIS 11
- Documentation
 - this operating instructions manual
 - Ex specific safety instructions (with Ex versions), if necessary further certificates

Components

VEGADIS 11 consists of the following components:

- Housing with integrated adjustment insert
- Housing cover with integrated indicating module

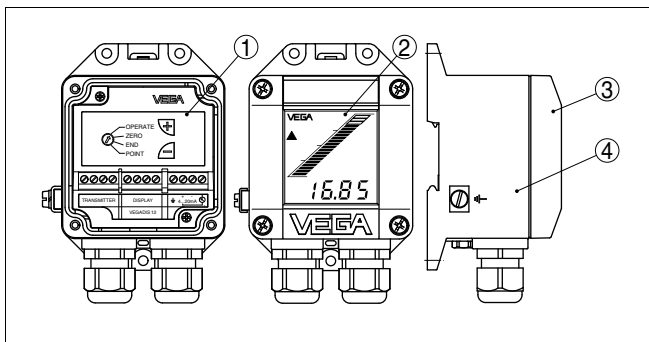

Fig. 1: VEGADIS 11

- 1 Adjustment insert
- 2 Indication
- 3 Cover
- 4 Housing

3.2 Principle of operation

Area of application

VEGADIS 11 is a digital indicating instrument for measured value indication in 4 ... 20 mA circuits. The measured value is displayed digitally or as bargraph via the LC display. The digital indication can be scaled. VEGADIS 11 is suitable for wall and carrier rail mounting.

Supply

VEGADIS 11 is looped directly into the 4 ... 20 mA circuits and requires no separate external energy. Connection is carried out via screw terminals in the housing.

3.3 Operation

For scaling the indication, VEGADIS 11 is equipped with an adjustment module. Adjustment is carried out via a rotary switch and two keys.

3.4 Packaging, transport and storage

Packaging

Your instrument was protected by packaging during transport. Its capacity to handle normal loads during transport is assured by a test according to DIN EN 24180.

The packaging of standard instruments consists of environment-friendly, recyclable cardboard. For special versions, PE foam or PE foil is also used. Dispose of the packaging material via specialised recycling companies.

Transport

Transport must be carried out under consideration of the notes on the transport packaging. Nonobservance of these instructions can cause damage to the device.

Transport inspection

The delivery must be checked for completeness and possible transit damage immediately at receipt. Ascertained transit damage or concealed defects must be appropriately dealt with.

Storage

Up to the time of installation, the packages must be left closed and stored according to the orientation and storage markings on the outside.

Unless otherwise indicated, the packages must be stored only under the following conditions:

- Not in the open
- Dry and dust free
- Not exposed to corrosive media
- Protected against solar radiation
- Avoiding mechanical shock and vibration

Storage and transport temperature

- Storage and transport temperature see "*Supplement - Technical data - Ambient conditions*"
- Relative humidity 20 ... 85 %

4 Mounting

4.1 General instructions

Installation position	VEGADIS 11 can be mounted in any position. However, vertical mounting is recommended. By doing so, penetration of moisture can be avoided.
Moisture	Use the recommended cables (see chapter " <i>Connecting to power supply</i> ") and tighten the cable gland.

4.2 Mounting instructions

Mounting versions	VEGADIS 11 can be mounted as follows: <ul style="list-style-type: none">● on carrier rail 35 x 7.5 according to EN 50022● on mounting plate or on the wall
--------------------------	---

5 Connecting to power supply

5.1 Preparing the connection

Note safety instructions

Always keep in mind the following safety instructions:

- Connect only in the complete absence of line voltage

Take note of safety instructions for Ex applications



In hazardous areas you should take note of the appropriate regulations, conformity and type approval certificates of the sensors and power supply units.

Selecting connection cable

VEGADIS 11 is connected with standard two-wire cable without screen.

An outer cable diameter of 5 ... 9 mm ensures the seal effect of the cable entry. If electromagnetic interference is expected which is above the test values of EN 61326 for industrial areas, we recommend the use of screened cable.

Select connection cable for Ex applications



Take note of the corresponding installation regulations for Ex applications.

Cable screening and grounding

If screened cable is necessary, connect the cable screen on both ends to ground potential. In the VEGADIS 11, the screen must be connected directly to the internal ground terminal. The ground terminal on the outside of the housing must be connected to the potential equalisation (low impedance).

If potential equalisation currents are expected, the connection on the processing side must be made via a ceramic capacitor (e. g. 1 nF, 1500 V). The low frequency potential equalisation currents are thus suppressed, but the protective effect against high frequency interference signals remains.

Cable screen and grounding for Ex applications

In Ex applications, one-sided grounding on the sensor is recommended, see EN 60079-14.

5.2 Connection procedure

Proceed as follows:

- 1 Unscrew the housing cover
- 2 Loosen compression nut of the cable entry
- 3 Remove approx. 10 cm of the cable mantle, strip approx. 1 cm insulation from the individual wires
- 4 Insert the cable into VEGADIS 11 through the cable entry

- 5 Loosen the screwed terminals with a screwdriver
 - 6 Insert the wire ends into the open terminals according to the wiring plan
 - 7 Tighten screw terminals again
 - 8 Check the hold of the wires in the terminals by lightly pulling on them
 - 9 Connect the screen to the ground terminal
 - 10 Connect the ground terminal outside on the housing according to specification (low impedance)
 - 11 Tighten the compression nut of the cable entry. The seal ring must completely encircle the cable
 - 12 Screw the housing cover on
- The electrical connection is finished.

5.3 Wiring plan

Passive sensors

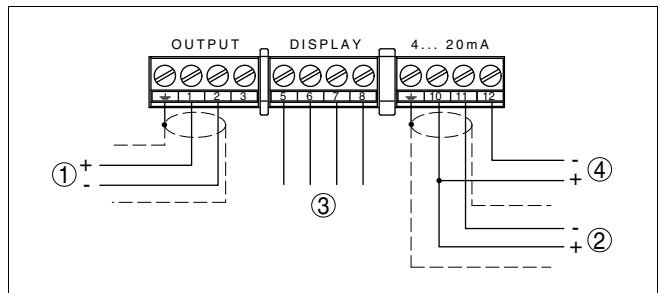

Fig. 2: Wiring plan - passive sensor

- 1 To the sensor
- 2 To power supply or the processing system
- 3 for indication
- 4 Control instrument (4 ... 20 mA measurement)

**Active sensors, sensors
with signal conditioning
instrument**

Fig. 3: Wiring plan - active sensor

- 1 To the sensor or to the signal conditioning instrument
- 2 for indication
- 3 Control instrument (4 ... 20 mA measurement)

6 Set up

6.1 Adjustment system

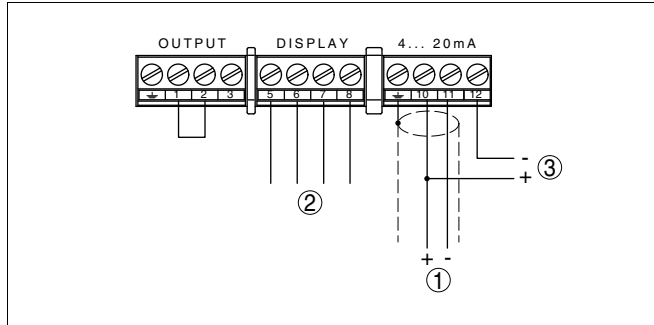
Adjustment elements

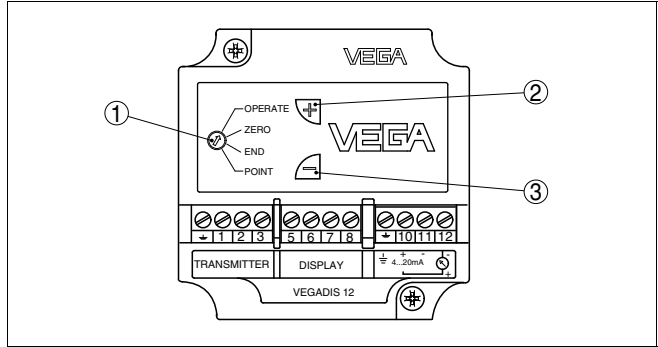

Fig. 4: Adjustment elements of VEGADIS 11

- 1 Rotary switch: choose the requested function
- 2 [+/-] key, change value (rising)
- 3 [-/-] key, change value (falling)

Adjustment volume

- operate - operation
- zero - adjustment of the min. value (4 mA)
- span - adjustment of the max. value (20 mA)
- point - shifting of the decimal point

Adjustment system

- The desired function is selected with the rotary switch
- With the [+/-] and [-/-] keys the signal current or the integration time is set or the indication is scaled
- The respective rotary switch is finally set to position "OPERATE"

The set values are transmitted to the EEPROM memory and remain there even in case of voltage loss.

6.2 Indication scaling

Preparation

For scaling the indication, it is recommended to screw the housing cover laterally or displaced to the bottom on the housing.

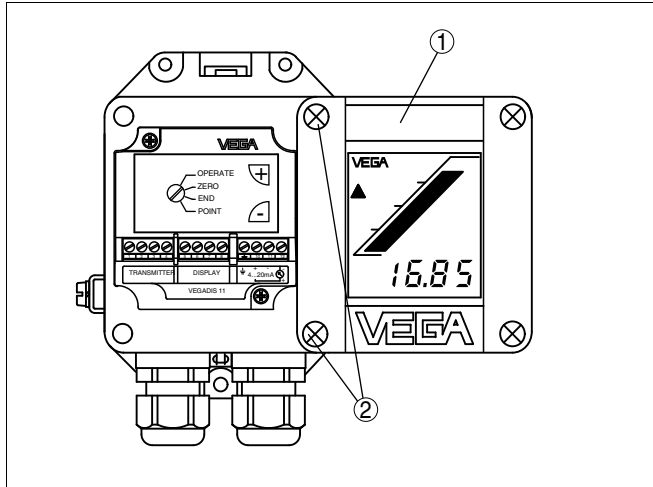

Fig. 5: With an individual instrument

- 1 Indicating module
- 2 Fixing screws

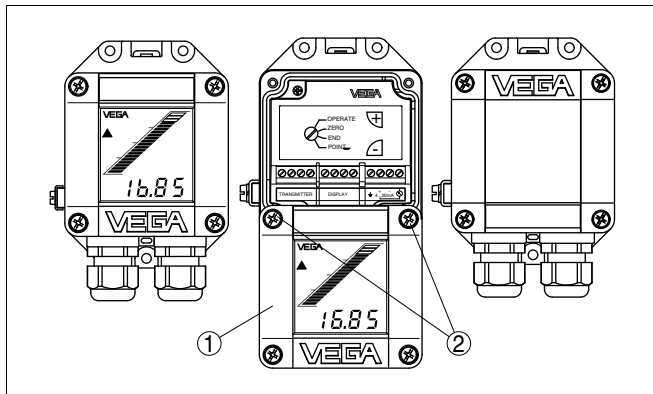

Fig. 6: With several instruments mounted next to each other

- 1 Indicating module
- 2 Fixing screws

Indicating elements

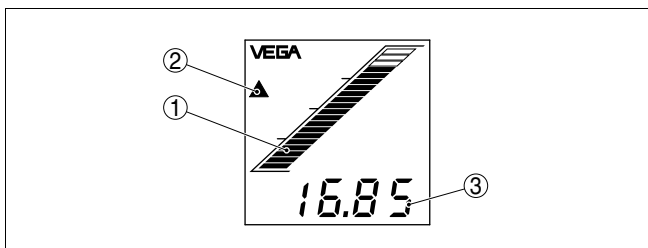

Fig. 7: Indicating elements of VEGADIS 11

- 1 Bar graph
- 2 Tendency indication
- 3 Digital value
 - four positions as well as signa and decimal point
 - individual scaling between -9999 ... +9999

The display outputs the current 4 ... 20 mA as bar graph and digital value.

With 4 mA no segment of the bar graph appears, with 20 mA all segments appear. This assignment is fix.

You can scale the digital value to any value between -9999 ... +9999 via the adjustment module.

Adjustment steps, scaling

To scale the indication, proceed as follows:

- 1 Initial value: Set rotary switch to "zero"
- 2 Set the requested value, e.g. 0 with the **[+]** and **[-]** keys
- 3 Final value: Set the rotary switch to "span"
- 4 Set the requested value, e.g. 1000 with the **[+]** and **[-]** keys
- 5 Decimal point: Set the rotary switch to "point"
- 6 With the **[+]** and **[-]** keys you can adjust the requested value, e.g. 8888 (no decimal point)
- 7 Set rotary switch to "OPERATE"
- 8 Screw the housing cover on

The adjustment data are effective, the output current 4 ... 20 mA corresponds to the actual level.

7 Maintenance and fault rectification

7.1 Maintenance

When used as directed in normal operation, VEGADIS 11 is completely maintenance free.

7.2 Remove interferences

Reaction when malfunctions occur	The operator of the system is responsible for taken suitable measures to remove interferences.
Causes of malfunction	<p>VEGADIS 11 offers maximum reliability. Nevertheless, faults can occur during operation. These may be caused by the following, e.g.:</p> <ul style="list-style-type: none"> ● Sensor ● Process ● Supply ● Signal processing
Fault clearance	The first measure is checking the output signal. The procedure is described below. Further comprehensive diagnostics options offer a PC with the software PACTware™ and the suitable DTM. In many cases, the reasons can be determined in this way and faults can be rectified.
24 hour service hotline	<p>However, should these measures not be successful, call the VEGA service hotline in urgent cases under the phone no. +49 1805 858550.</p> <p>The hotline is available to you 7 days a week round-the-clock. Since we offer this service world-wide, the support is only available in the English language. The service is free of charge, only the standard telephone costs will be charged.</p>
Checking the 4 ... 20 mA signal	<p>Connect a handheld multimeter in the suitable measuring range according to the wiring plan.</p> <p>? 4 ... 20 mA signal not stable</p> <ul style="list-style-type: none"> ● Level fluctuations <ul style="list-style-type: none"> → Adjust integration time via PACTware™ ● No atmospheric pressure compensation with pressure transmitters <ul style="list-style-type: none"> → Check pressure compensation

- ? 4 ... 20 mA signal missing
 - Wrong connection to power supply
 - Check connection according to chapter "*Connection steps*" and if necessary, correct according to chapter "*Wiring plan*"
 - No voltage supply
 - Check cables for breaks; repair if necessary
 - supply voltage too low or load resistance too high
 - Check, adapt if necessary

- ? Current signal 3.6 mA; 22 mA
 - Oscillator in the sensor defective
 - Exchange instrument or return instrument for repair



Reaction after fault rectification

In Ex applications, the regulations for the wiring of intrinsically safe circuits must be observed.

Depending on the failure reason and measures taken, the steps described in chapter "*Set up*" must be carried out again, if necessary.

7.3 Instrument repair

If a repair is necessary, please proceed as follows:

You can download a return form (23 KB) from our Internet homepage www.vega.com under: "*Downloads - Forms and certificates - Repair form*".

By doing this you help us carry out the repair quickly and without having to call back for needed information.

- Print and fill out one form per instrument
- Clean the instrument and pack it damage-proof
- Attach the completed form and, if need be, also a safety data sheet outside on the packaging
- Please ask the agency serving you for the address of your return shipment. You can find the respective agency on our website www.vega.com under: "*Company - VEGA worldwide*"

8 Dismounting

8.1 Dismounting steps



Warning:

Before dismounting, be aware of dangerous process conditions such as e.g. pressure in the vessel, high temperatures, corrosive or toxic products etc.

Take note of chapters "*Mounting*" and "*Connecting to power supply*" and carry out the listed steps in reverse order.

8.2 Disposal

The instrument consists of materials which can be recycled by specialised recycling companies. We use recyclable materials and have designed the electronics to be easily separable.

WEEE directive 2002/96/EG

This instrument is not subject to the WEEE directive 2002/96/EG and the respective national laws. Pass the instrument directly on to a specialised recycling company and do not use the municipal collecting points. These may be used only for privately used products according to the WEEE directive.

Correct disposal avoids negative effects to persons and environment and ensures recycling of useful raw materials.

Materials: see chapter "*Technical data*"

If you cannot dispose of the instrument properly, please contact us about disposal methods or return.

9 Supplement

9.1 Technical data

General data

316L corresponds to 1.4404 or 1.4435, 316Ti corresponds to 1.4571

Materials

- Housing plastic PBT
- Ground terminal 316Ti/316L
- Inspection window of the indication

Weight approx. 0.5 kg (1.102 lbs)

Ambient conditions

Ambient temperature -20 ... +70 °C (-40 ... +158 °F)

Storage and transport temperature -40 ... +85 °C (-40 ... +185 °F)

Electromechanical data

Cable gland 2 x cable entry M20 x 1.5 (cable: ø 5 ... 9 mm)

Screw terminals for cable cross-section up to 2.5 mm² (AWG 14)

Adjustment and indicating elements

Adjustment elements 2 keys, 1 rotary switch

Indication LC multiple function display with bar graph (20 segments, digital value 4-digit), tendency indicator for rising or falling values

Voltage supply

Supply voltage 17 ... 36 V DC

Electrical protective measures

Protection IP 65

Overvoltage category III

Protection class III

Approvals¹⁾

ATEX ia ATEX II 2G EEx ia IIC T6

¹⁾ Deviating data in Ex applications: see separate safety instructions.

9.2 Dimensions

VEGADIS 11

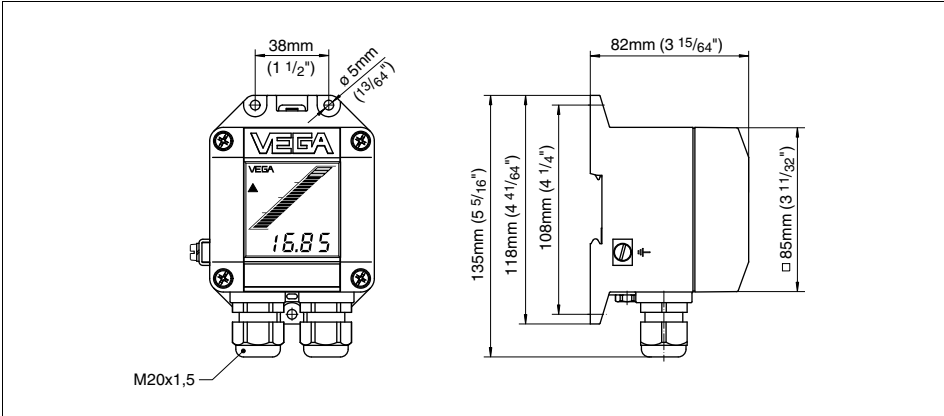

Fig. 8: VEGADIS 11

9.3 Industrial property rights

VEGA product lines are global protected by industrial property rights. Further information see <http://www.vega.com>.

Only in U.S.A.: Further information see patent label at the sensor housing.

VEGA Produktfamilien sind weltweit geschützt durch gewerbliche Schutzrechte.

Nähere Informationen unter <http://www.vega.com>.

Les lignes de produits VEGA sont globalement protégées par des droits de propriété intellectuelle. Pour plus d'informations, on pourra se référer au site <http://www.vega.com>.

VEGA líneas de productos están protegidas por los derechos en el campo de la propiedad industrial. Para mayor información revise la pagina web <http://www.vega.com>.

Линии продукции фирмы ВЕГА защищаются по всему миру правами на интеллектуальную собственность.

Дальнейшую информацию смотрите на сайте <http://www.vega.com>.

VEGA系列产品在全球享有知识产权保护。

进一步信息请参见网站<<http://www.vega.com>>。

9.4 Trademark

All brands used as well as trade and company names are property of their lawful proprietor/originator.



Printing date:

VEGA Grieshaber KG
Am Hohenstein 113
77761 Schiltach
Germany
Phone +49 7836 50-0
Fax +49 7836 50-201
E-mail: info@de.vega.com
www.vega.com



All statements concerning scope of delivery, application, practical use and operating conditions of the sensors and processing systems correspond to the information available at the time of printing.

© VEGA Grieshaber KG, Schiltach/Germany 2008