

Monitoring technique

Underload monitor (cos φ monitor) IK 9065, SK 9065, SL 9065CT varimeter

SL 9065CT
for currents up to 100 A



0246036

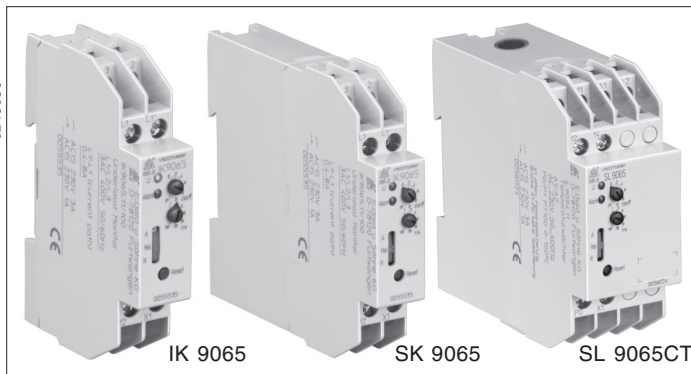

- According to IEC/EN 60 255, DIN VDE 0435-303
- Detection of underload (cos φ)
- Without auxiliary supply
- Current up to 8 A
- Motors up to 5 A nominal current can be connected directly
- Higher currents via current transformer
- SL 9065CT with integrated current transformer for currents up to 100 A
- Adjustable response value
- Automatic reset (Alarm auto reset)
- Adjustable operate delay up to 100 s
- De-energised on trip
- For single and 3-phase loads e.g. motors
- Independent of phase sequence
- 1 changeover contact
- LED indicator voltage supply and alarm
- **Devices available in 2 enclosure versions: IK 9065: depth 58 mm, with terminals at the bottom for installation systems and industrial distribution systems according to DIN 43 880**
- **SK 9065, SL 9065CT: depth 98 mm, with terminals at the top for cabinets with mounting plate and cable duct**
- IK 9065, SK 9065 width 17.5 mm
- SL 9065CT width 35 mm

Function diagram

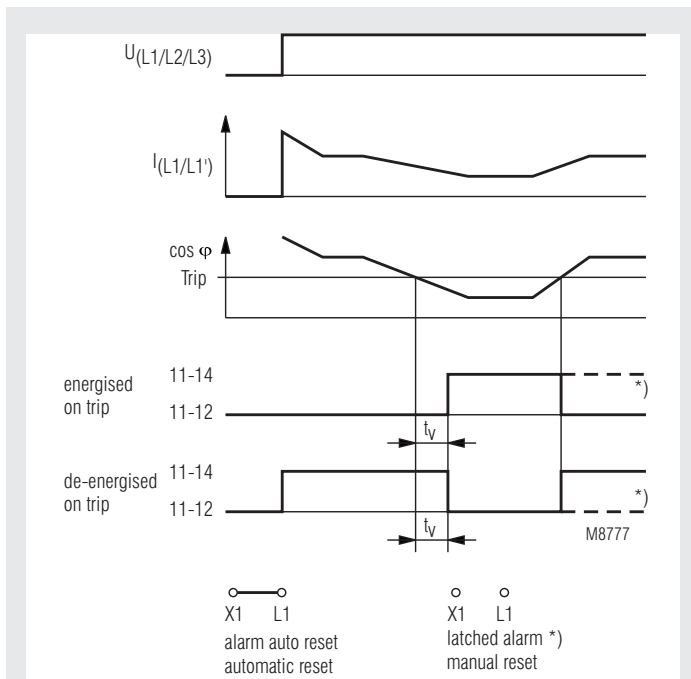

- IK/SK 9065/100: as IK/SK 9065 but:
- programmable for
 - automatic reset or manual reset (latched alarm)
 - energised or de-energised on trip
 - with reset button
 - remote reset

Approvals and marking



Applications

- Monitors underload and no load on squirrel cage motors e.g.
- fan monitoring (broken belt)
 - filter monitoring (blocked filter)
 - pump monitoring (blocked valve, dry running)
 - general cos phi monitoring

Function

The underload monitor IK/SK/SL 9065 measures the phase shift between voltage and current. The phase angle changes with changing load. This measuring method is suitable to monitor asynchronous motors on underload and no load independent of motor size. In some cases the cos φ does not change much with load change on the motor, e.g.:

- small load change on oversized motor
- single phase shaded-pole and collector motors

In these cases we recommend the use of motor load monitor BA 9067 or BH 9097.

If a cos φ value lower then the adjusted value is detected the output relay changes into alarm state after the adjusted time delay t_v and the red LED "Alarm" lights up. If the underload monitor is in auto reset mode it changes back to normal state without delay when the cos φ rises above the adjusted cos φ value.

Indicators

- green LED: on, when supply connected to L1-L2
- red LED: on, when underload detected (Alarm)

Circuit diagram

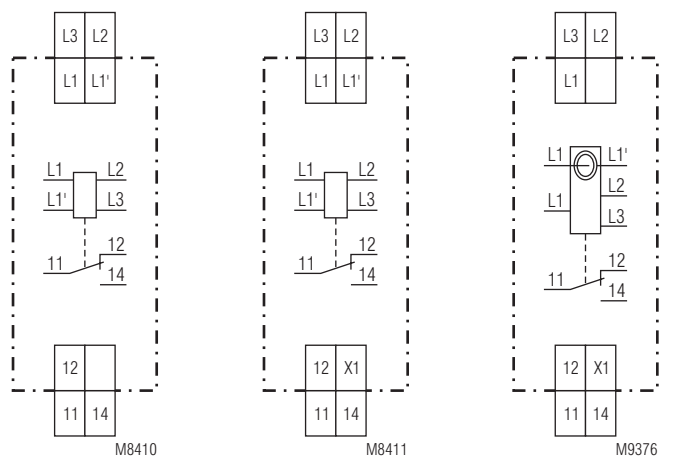

IK/SK 9065.11

IK/SK 9065.11/100

SL 9065.11CT/100

Adjustment

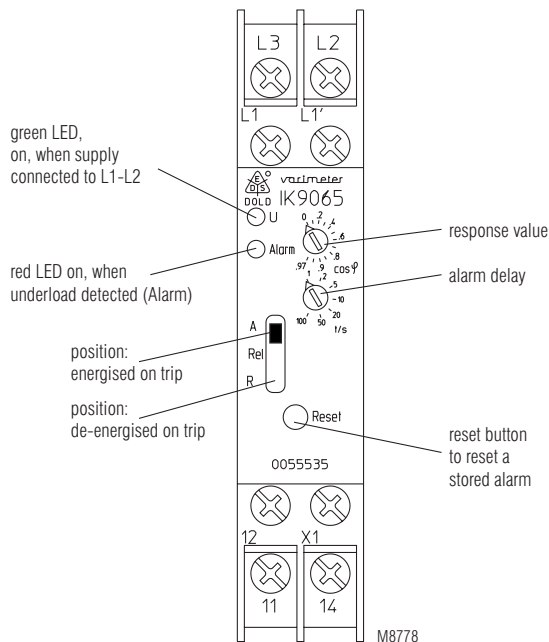

Remarks

Monitoring of single phase load is also possible. The terminal L3 is not connected in this case (see connection diagram). The underload monitor must be ordered for the right voltage e.g. a unit for 3 AC 230 V for a single phase 230 V application.

When the underload monitor IK/SK 9065 is connected to the supply voltage L1-L2-L3 and no current is flowing in the current path L1-L1' the unit changes also in alarm state.

The current path L1-L1' allows to connect currents up to 8 A directly at IK/SK 9065. When connecting asynchronous motors not only the nominal current is important, but also the much higher starting current. The overload characteristic of the current input allows to connect motors with nominal current up to 4..5 A depending on the starting conditions. This is at 3 AC 400 V a motor load of 1.5 ... 2.2 kW.

It is important that the motor is connected to L1' and **not** to L1. On wrong connection the phase angle will be measured in a wrong way and the underload monitor IK/SK 9065 will not work.

For higher currents over 8 A (nominal motor current over 5 A) external current transformers can be used (see connection examples). Also here the current transformers have to be connected with the right polarity. All standard current transformers of class 3 or better can be used (1 A or 5 A types).

The integrated current transformer at SL 9065CT allows to connect currents up to 100 A directly.

The variant IK/SK/SL 9065.11/100 allows the following settings:

Bridge

X1-L1

- Automatic restart (Alarm auto reset)
- ● Manual restart (Latched Alarm), reset with built in push button, external push button on X1-L1 or by disconnecting the supply voltage.

Switch "REL" on front side

- position "A": energised on trip (relay energises on underload-alarm)
- Position "R": de-energised on trip (relay de-energises on underload-alarm)

Technical data

Input

Nominal voltage U_N:	(= Motor voltage) 3 AC (or AC) 110, 230, 400 V
Voltage range:	0.8 ... 1.1 U_N
Nominal frequency of U_N:	45 ... 65 Hz
Nominal consumption (L1-L2):	max. ca. 11 VA

Current path

Current range IK 9065, SK 9065:	0.1 ... 2 A	0.5 ... 8 A*
Internal resistance:	approx. 30 mΩ	approx. 10 mΩ
Consumption:	max. 0.14 VA	max. 0.7 VA
	* (for higher currents use external current transformer see connection diagram)	
Short time overload:	2.5 x I_{max} for 2 s, 5 x I_{max} for 0.5 s	
Suitable current transformers:	1 A or 5 A types, class 3, with necessary load capacity	
Current range SL 9065CT:	5 ... 100 A via integrated current transformer in the base	
Setting range $\cos \varphi$:	0 ... 0.97 infinite variable	
Operate delay t_v:	1 ... 100 s infinite variable	

Output

Contacts	IK 9065.11, SK 9065.11:	1 changeover contact
Thermal current I_{th}:		4 A
Switching capacity		
to AC 15		
NO contact:	3 A / AC 230 V	IEC/EN 60 947-5-1
NC contact:	1 A / AC 230 V	IEC/EN 60 947-5-1
to DC 13:	1 A / DC 24 V	IEC/EN 60 947-5-1
Electrical life		
to AC 15 at 1 A, AC 230 V:	1.5 x 10 ⁵ switching cycles	IEC/EC 60 947-5-1
Short-circuit strength		
max. fuse rating:	4 A gL	IEC/EN 60 947-5-1
Mechanical life:	30 x 10 ⁶ switching cycles	

General data

Operating mode:	Continuous operation	
Temperature range:	- 40 ... + 60°C	
Clearance and creepage distances		
overvoltage category / contamination level:	4 kV / 2	IEC 60 664-1
EMC		
Electrostatic discharge:	8 kV (air)	IEC/EN 61 000-4-2
HF-irradiation:	20 V/m	IEC/EN 61 000-4-3
Fast transients:	4 kV	IEC/EN 61 000-4-4
Surge voltages		
between		
wires for power supply:	2 kV	IEC/EN 61 000-4-5
HF-wire guided:	10 V	IEC/EN 61 000-4-6
Interference suppression:	Limit value class B	EN 55 011
Degree of protection:	Housing: IP 40	IEC/EN 60 529
	Terminals: IP 20	IEC/EN 60 529
Housing:	Thermoplastic with V0 behaviour according to UL subject 94	
Vibration resistance:	Amplitude 0.35 mm frequency 10 ... 55 Hz IEC/EN 60 068-2-6	
	40 / 060 / 04	IEC/EN 60 068-1
Climate resistance:	EN 50 005	
Terminal designation:	EN 50 005	
Wire connection:	2 x 2.5 mm ² solid or 2 x 1.5 mm ² stranded wire with sleeve DIN 46 228-1/-2/-3/-4	
Wire fixing:	Flat terminals with self-lifting clamping piece IEC/EN 60 999-1	
Mounting:	DIN rail IEC/EN 60 715	
Weight:	IK 9065:	approx 65 g
	SK 9065:	approx 84 g
	SL 9065CT:	approx. 195 g

Dimensions

IK 9065:	17.5 x 90 x 58 mm
SK 9065:	17.5 x 90 x 98 mm
SL 9065CT:	35 x 90 x 98 mm

Width x height x depth:

Standard types

IK 9065.11 3 AC 400 V 0.4 ... 8 A 1 ... 100 s
 Article number: 0055534
 • Output: 1 changeover contact
 • De-energised on trip:
 • Nominal voltage U_N : 3 AC 400 V
 • Current range: 0.4 ... 8 A
 • Operate delay: 1 ... 100 s
 • Width: 17.5 mm

SK 9065.11 3 AC 400 V 0.4 ... 8 A 1 ... 100 s
 Article number: 0055816
 • Output: 1 changeover contact
 • De-energised on trip:
 • Nominal voltage U_N : 3 AC 400 V
 • Current range: 0.4 ... 8 A
 • Operate delay: 1 ... 100 s
 • Width: 17.5 mm

SL 9065.11CT/100 3 AC 400 V 5 ... 100 A 1 ... 100 s
 Article number: 0059410
 • Output: 1 changeover contact
 • Nominal voltage U_N : 3 AC 400 V
 • Current range: 5 ... 100 A
 • Operate delay: 1 ... 100 s
 • programmable for: manual reset with built in or external push button, energised or de-energised on trip, selection via switch on the front
 • Width: 35 mm

Variants

IK 9065.11/100,
 SK 9065.11/100: programmable for: manual reset with built in or external push button, energised or de-energised on trip, selection via switch on the front

Ordering example for variants

IK 9065 .11 / _ _ _ 3 AC 400 V 0.4 ... 8 A 1 ... 100 s

Operate delay
 Current range
 Nominal voltage
 Variant, if required
 Contacts
 Type

Connection examples

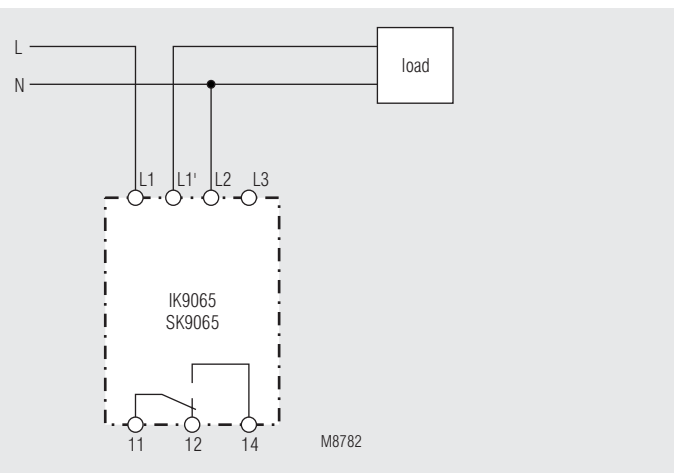

IK 9065.11 with single-phase load

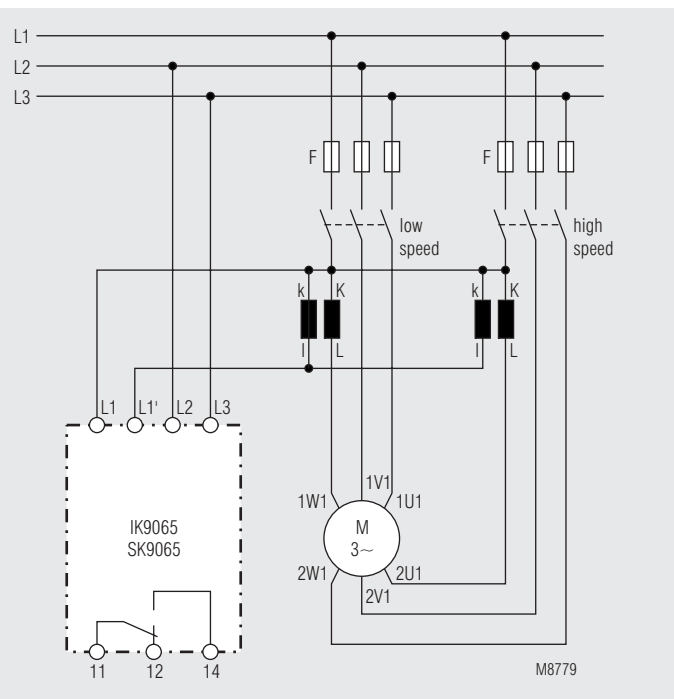

IK/SK 9065.11 for motors with separate windings

Connection examples

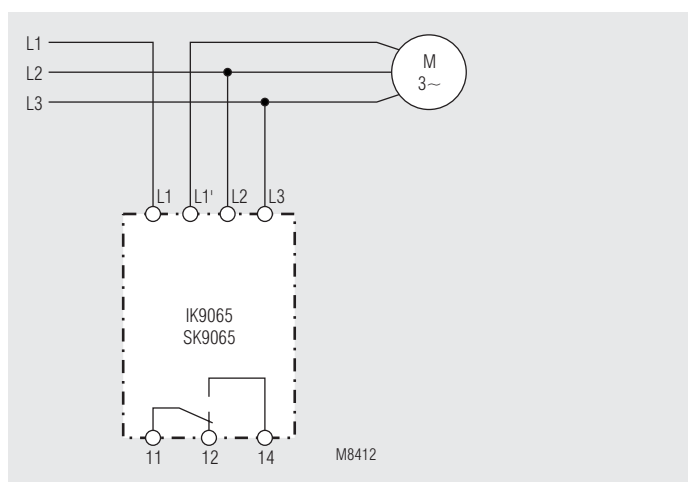

IK 9065.11 with 3-phase load

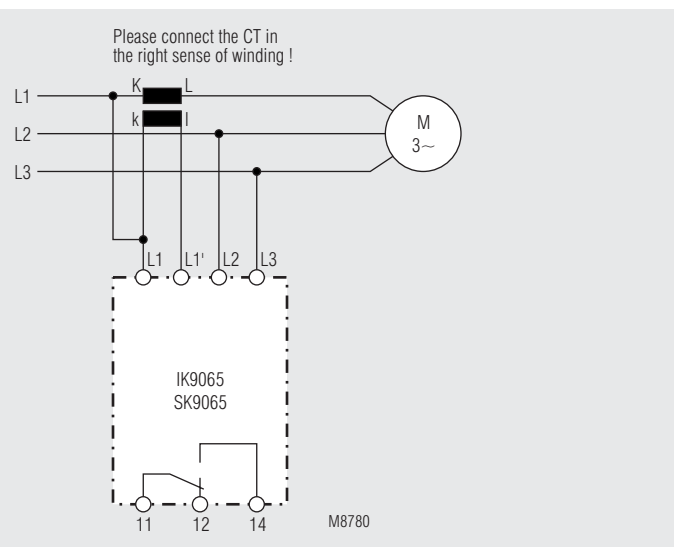

IK/SK 9065.11 with 3-phase load and external current transformer

Connection examples

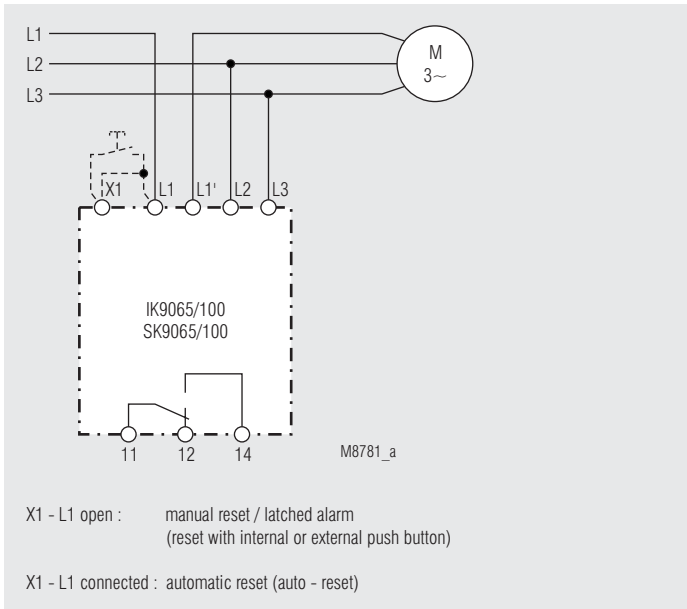

IK/SK 9065.11/100 with 3-phase load

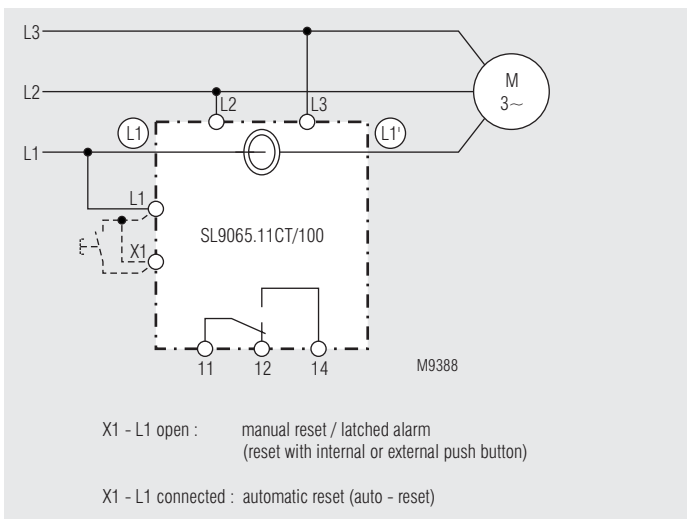

SL 9065.11CT/100