

Operating Instructions

VEGAWELL 52

4 ... 20 mA/HART Pt 100



Process pressure/
Hydrostatic

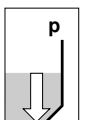

Contents

1	About this document	
1.1	Function	4
1.2	Target group	4
1.3	Symbolism used	4
2	For your safety	
2.1	Authorised personnel	5
2.2	Appropriate use	5
2.3	Warning about misuse	5
2.4	General safety instructions	5
2.5	Safety approval markings and safety tips	6
2.6	CE conformity	6
2.7	Fulfillment of NAMUR recommendations	6
2.8	Safety instructions for Ex areas	6
2.9	Environmental instructions	7
3	Product description	
3.1	Configuration	8
3.2	Principle of operation	10
3.3	Operation	10
3.4	Packaging, transport and storage	10
4	Mounting	
4.1	General instructions	12
4.2	Mounting steps with straining clamp	14
4.3	Mounting steps with screwed connection	15
4.4	Mounting steps with threaded connection or housing	16
5	Connecting to power supply	
5.1	Preparing the connection	18
5.2	Connection procedure	20
5.3	Wiring plan	21
5.4	Switch on phase	23
6	Setup with PACTware	
6.1	Connecting the PC	24
6.2	Parameter adjustment with PACTware	25
6.3	Saving the parameter adjustment data	25
7	Maintenance and fault rectification	
7.1	Maintain	26
7.2	Remove interferences	26
7.3	Shortening the suspension cable	27
7.4	Shortening the suspension cable	27
7.5	Instrument repair	29
8	Dismounting	
8.1	Dismounting steps	31

8.2	Disposal	31
9	Supplement	
9.1	Technical data	32
9.2	Dimensions	38

Supplementary documentation



Information:

Supplementary documents appropriate to the ordered version come with the delivery. You can find them listed in chapter "*Product description*".

Instructions manuals for accessories and replacement parts



Tip:

To ensure reliable setup and operation of your VEGAWELL 52, we offer accessories and replacement parts. The associated documents are:

- 32798 - VEGABOX 02

1 About this document

1.1 Function

This operating instructions manual provides all the information you need for mounting, connection and setup as well as important instructions for maintenance and fault rectification. Please read this information before putting the instrument into operation and keep this manual accessible in the immediate vicinity of the device.

1.2 Target group

This operating instructions manual is directed to trained qualified personnel. The contents of this manual should be made available to these personnel and put into practice by them.

1.3 Symbolism used



Information, tip, note

This symbol indicates helpful additional information.



Caution: If this warning is ignored, faults or malfunctions can result.

Warning: If this warning is ignored, injury to persons and/or serious damage to the instrument can result.

Danger: If this warning is ignored, serious injury to persons and/or destruction of the instrument can result.



Ex applications

This symbol indicates special instructions for Ex applications.



List

The dot set in front indicates a list with no implied sequence.



Action

This arrow indicates a single action.



Sequence

Numbers set in front indicate successive steps in a procedure.

2 For your safety

2.1 Authorised personnel

All operations described in this operating instructions manual must be carried out only by trained specialist personnel authorised by the plant operator.

During work on and with the device the required personal protective equipment must always be worn.

2.2 Appropriate use

VEGAWELL 52 is a suspension pressure transmitter for level and gauge measurement.

You can find detailed information on the application range in chapter "*Product description*".

Operational reliability is ensured only if the instrument is properly used according to the specifications in the operating instructions manual as well as possible supplementary instructions.

For safety and warranty reasons, any invasive work on the device beyond that described in the operating instructions manual may be carried out only by personnel authorised by the manufacturer. Arbitrary conversions or modifications are explicitly forbidden.

2.3 Warning about misuse

Inappropriate or incorrect use of the instrument can give rise to application-specific hazards, e.g. vessel overfill or damage to system components through incorrect mounting or adjustment.

2.4 General safety instructions

This is a high-tech instrument requiring the strict observance of standard regulations and guidelines. The user must take note of the safety instructions in this operating instructions manual, the country-specific installation standards as well as all prevailing safety regulations and accident prevention rules.

The instrument must only be operated in a technically flawless and reliable condition. The operator is responsible for trouble-free operation of the instrument.

During the entire duration of use, the user is obliged to determine the compliance of the required occupational safety measures with the current valid rules and regulations and also take note of new regulations.

2.5 Safety approval markings and safety tips

The safety approval markings and safety tips on the device must be observed.

2.6 CE conformity

The protection goals of the EMC Directive 2004/108/EC (EMC) and the Low Voltage Directive 2006/95/EC (LVD) are fulfilled.

Conformity has been judged according to the following standards:

EMC: EN 61326-1: 2006

(electrical instruments for control technology and laboratory use - EMC requirements)

- Emission: Class B
- Susceptibility: Industrial areas

LVD: EN 61010-1: 2001

(safety regulations for electrical measurement, control and laboratory instruments - part 1: General requirements)

The instrument is designed for use in an industrial environment. Nevertheless, electromagnetic interference from electrical conductors and radiated emissions must be taken into account, as is usual with a class A instrument according to EN 61326. If the instrument is used in a different environment, the electromagnetic compatibility to other instruments must be ensured by suitable measures.

2.7 Fulfillment of NAMUR recommendations

With respect to compatibility, the NAMUR recommendation NE 53 is fulfilled. This applies also to the corresponding indicating and adjustment components. VEGA instruments are generally upward and downward compatible.

- Sensor software for DTM VEGAWELL 52 HART
- DTM VEGAWELL 52 for adjustment software PACTware

The parameter adjustment of the basic sensor functions is independent of the software version. The range of available functions depends on the respective software version of the individual components.

The software version of the instrument can be read out via PACTware.

You can view all software histories on our website www.vega.com. Make use of this advantage and get registered for update information via e-mail.

2.8 Safety instructions for Ex areas

Please note the Ex-specific safety information for installation and operation in Ex areas. These safety instructions are part of the operating instructions manual and come with the Ex-approved instruments.

2.9 Environmental instructions

Protection of the environment is one of our most important duties. That is why we have introduced an environment management system with the goal of continuously improving company environmental protection. The environment management system is certified according to DIN EN ISO 14001.

Please help us fulfil this obligation by observing the environmental instructions in this manual:

- Chapter "*Packaging, transport and storage*"
- Chapter "*Disposal*"

3 Product description

3.1 Configuration

Scope of delivery

The scope of delivery encompasses:

- VEGAWELL 52 pressure transmitter with suspension cable
- optionally available with straining clamp, screwed connection or housing with cable locking
- Documentation
 - this operating instructions manual
 - test certificate
 - Ex-specific "*Safety instructions*" (with Ex-versions)
 - if necessary, further certificates

Components

VEGAWELL 52 with suspension cable consists of the following components:

- Transmitter
- Suspension cable
- Optionally fixing element or housing with threaded fitting

The components are available in different versions.

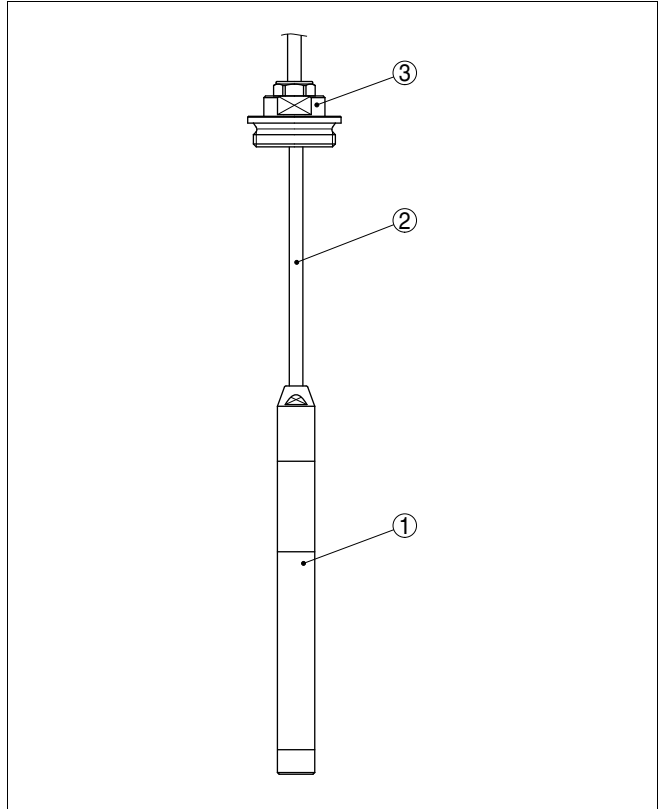

Fig. 1: Example of a VEGAWELL 52 with transmitter 22 mm and unassembled threaded fitting

- 1 Transmitter
- 2 Suspension cable
- 3 Screw connection

Type label

The type label contains the most important data for identification and use of the instrument:

- Article number
- Serial number
- Technical data
- Article numbers documentation

The serial number allows you to access the delivery data of the instrument via www.vega.com, "VEGA Tools" and "serial number search". You can also find the serial number on the type label on the suspension cable or on the housing.

3.2 Principle of operation

Application area	VEGAWELL 52 is used for level and gauge measurement in wells, basins and atmospherically open vessels particularly in the water/waste water industry as well as in the shipbuilding industry. ¹⁾
Functional principle	<p>The actual sensor element is the CERTEC® measuring cell with rugged ceramic diaphragm. The hydrostatic pressure causes a capacitance change in the measuring cell via the ceramic diaphragm. This change is converted into an appropriate output signal.</p> <p>The CERTEC® measuring cell is also equipped with a temperature sensor Pt 100 in four-wire technology. The resistance value is accessed via the wires of the suspension cable. The power supply or the processing is carried out via a temperature transducer, e.g. in the VEGABOX 02.</p>
Power supply	<p>Two-wire electronics 4 ... 20 mA/HART for power supply and measured value transmission over the same cable.</p> <p>The supply voltage range can differ depending on the instrument version.</p> <p>The data for power supply are specified in chapter "<i>Technical data</i>".</p>

3.3 Operation

VEGAWELL 52 - 4 ... 20 mA/HART can be adjusted with different adjustment media:

- an adjustment software according to FDT/DTM standard, e.g. PACTware and PC
- With a HART handheld

The type of adjustment and the adjustment options depend on the selected adjustment component. The entered parameters are generally saved in the respective sensor, when adjusting with PACTware™ and PC optionally also in the PC.

3.4 Packaging, transport and storage

Packaging	<p>Your instrument was protected by packaging during transport. Its capacity to handle normal loads during transport is assured by a test according to DIN EN 24180.</p> <p>The packaging of standard instruments consists of environment-friendly, recyclable cardboard. For special versions, PE foam or PE foil is also used. Dispose of the packaging material via specialised recycling companies.</p>
------------------	---

¹⁾ For use in closed vessels under vacuum, the instrument is available with absolute pressure measuring ranges.

Transport	Transport must be carried out under consideration of the notes on the transport packaging. Nonobservance of these instructions can cause damage to the device.
Transport inspection	The delivery must be checked for completeness and possible transit damage immediately at receipt. Ascertained transit damage or concealed defects must be appropriately dealt with.
Storage	<p>Up to the time of installation, the packages must be left closed and stored according to the orientation and storage markings on the outside.</p> <p>Unless otherwise indicated, the packages must be stored only under the following conditions:</p> <ul style="list-style-type: none">● Not in the open● Dry and dust free● Not exposed to corrosive media● Protected against solar radiation● Avoiding mechanical shock and vibration
Storage and transport temperature	<ul style="list-style-type: none">● Storage and transport temperature see chapter "<i>Supplement - Technical data - Ambient conditions</i>"● Relative humidity 20 ... 85 %

4 Mounting

4.1 General instructions

Suitability for process conditions

Make sure that all parts of the instrument in contact with the measured product, especially the sensor element, process seal and process fitting, are suitable for the existing process conditions such as process pressure, process temperature as well as the chemical properties of the medium.

You can find the specifications in chapter "*Technical data*" in the or on the type label.

Mounting position

Note the following points when selecting the installation location.

- Sideways movements of the transmitter can cause measurement errors
- Therefore, mount VEGAWELL 52 in a calm area or in a suitable protective tube



Information:

We recommend the measuring instrument holder from the VEGA line of accessory (article no. BARMONT.D or BARMONT.E) to fasten VEGAWELL 52.

- The protective cover prevents mechanical damage to the measuring cell. It should only be removed when the sensor is deployed in extremely polluted water.

Pressure compensation

- The connection cable has a capillary for atmospheric pressure compensation
- Therefore lead the cable end into a dry space or directly into a suitable terminal housing.



Information:

For this purpose, VEGA recommends VEGABOX 02. It contains terminals and a filter element for pressure compensation. A suitable protective cover is available for outdoor mounting.

Mounting example

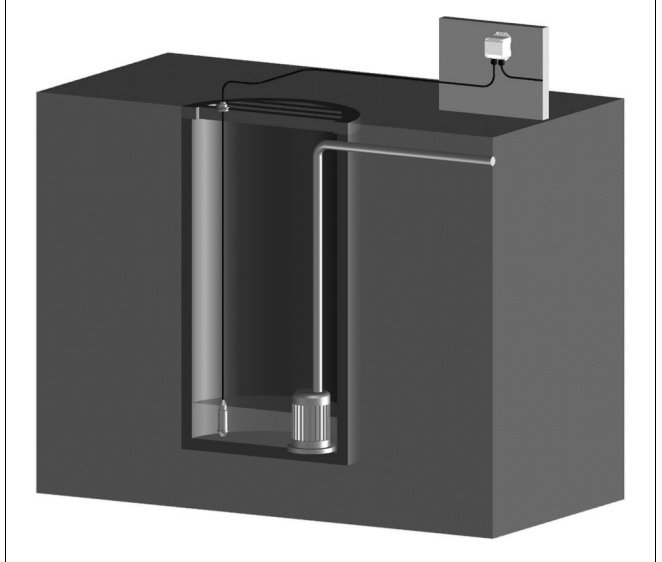

Fig. 2: Mounting example: VEGAWELL 52 in a pump shaft with breather housing VEGABOX 02

4.2 Mounting steps with straining clamp

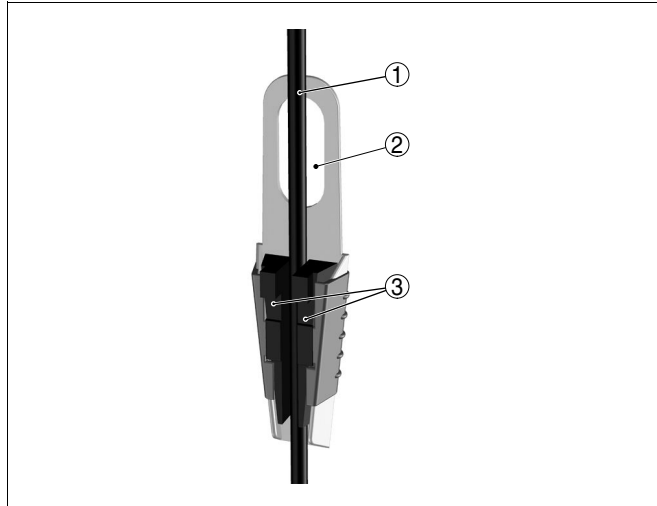

Fig. 3: Straining clamp

- 1 Suspension cable
- 2 Suspension opening
- 3 Clamping jaws

Mount VEGAWELL 52 with straining clamp as follows:

- 1 Hang the straining clamp on a suitable wall hook
- 2 Lower VEGAWELL 52 to the requested height
- 3 Slide the clamping jaws upward and push the suspension cable between them
- 4 Hold the suspension cable, push the clamping jaws downward and fix them with a light blow

Removal is carried out in reverse order.

4.3 Mounting steps with screwed connection

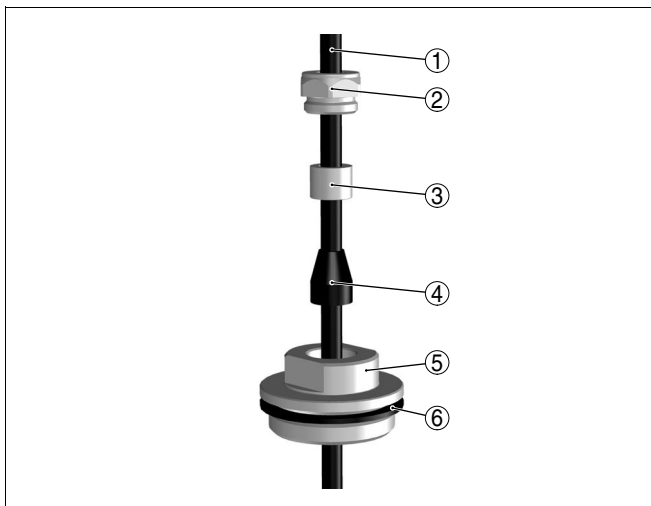

Fig. 4: Screw connection

- 1 Suspension cable
- 2 Seal screw
- 3 Cone bushing
- 4 Seal cone
- 5 Screw connection
- 6 Seal

Mount VEGAWELL 52 with screwed connection as follows:

- 1 Weld the welded socket into the vessel top
- 2 Lower VEGAWELL 52 to the requested height by means on the welded socket G1½ A or 1½ NPT on the vessel side
- 3 Insert the suspension cable from below into the open screwed connection
- 4 Slide the seal cone and the cone sleeve over the suspension cable, fasten manually with the seal screw
- 5 Screw the screwed connection into the socket, fasten with SW 30 and then fasten seal screw with SW 19

How to correct the height:

- 1 Loosen seal screw with SW 19
- 2 Slide seal cone and cone sleeve to the requested position on the cable
- 3 Fasten the seal screw

Removal is carried out in reverse order.

4.4 Mounting steps with threaded connection or housing



Fig. 5: Plastic housing

- 1 Housing
- 2 Seal
- 3 Thread

Mount into the vessel

Mount VEGAWELL 52 as follows:

- 1 Weld the welded socket G1½ A or 1½ NPT to the vessel top
 - 2 Shift transmitter through the mounting boss
 - 3 Turn the thread with seal into the socket and tighten with SW 46²⁾
- Removal is carried out in reverse order.

Mounting into the basin

Mount VEGAWELL 52 as follows:

- 1 Fasten the mounting bracket at the suitable height on the basin wall



Information:

We recommend articles from the line of VEGA accessories:

- Mounting angle of stainless steel
- Counter nut of PP

²⁾ Seal the 1½ NPT thread with teflon, hemp or a similar resistant material.

- 2 Lead the transmitter through the opening of the mounting bracket and the counter nut
- 3 Fasten the counter nut to the thread with SW 46

5 Connecting to power supply

5.1 Preparing the connection

Note safety instructions

Always keep in mind the following safety instructions:

- Connect only in the complete absence of line voltage
- If overvoltage surges are expected, overvoltage arresters should be installed



Tip:

We recommend the following VEGA overvoltage arresters:

- B63-48 (use in plastic housing of VEGAWELL 52)
- ÜSB 62-36G.X (use in a separate housing)

Take note of safety instructions for Ex applications



In hazardous areas you should take note of the appropriate regulations, conformity and type approval certificates of the sensors and power supply units.

Select power supply

Power supply and current signal are carried on the same two-wire cable. The voltage supply range can differ depending on the instrument version.

The data for power supply are specified in chapter "*Technical data*".

Provide a reliable separation between the supply circuit and the mains circuits according to DIN VDE 0106 part 101.

VEGA power supply units VEGATRENN 149AEx, VEGASTAB 690, VEGADIS 371 as well as all VEGAMETs meet this requirement. When using one of these instruments, protection class III is ensured for VEGAWELL 52.

Keep in mind the following additional influences on the operating voltage:

- Output voltage of the power supply unit can be lower under nominal load (with a sensor current of 20.5 mA or 22 mA in case of fault message)
- Influence of additional instruments in the circuit (see load values in chapter "*Technical data*")

Selecting connection cable

The instrument is connected with standard two-wire cable without screen. If electromagnetic interference is expected which is above the test values of EN 61326 for industrial areas, screened cable should be used.

Use cable with round cross-section. A cable outer diameter of 5 ... 9 mm (0.2 ... 0.35 in) ensures the seal effect of the cable gland. If you are using cable with a different diameter or cross-section, exchange the seal or use a suitable cable gland.

We generally recommend the use of screened cable for HART multidrop mode.

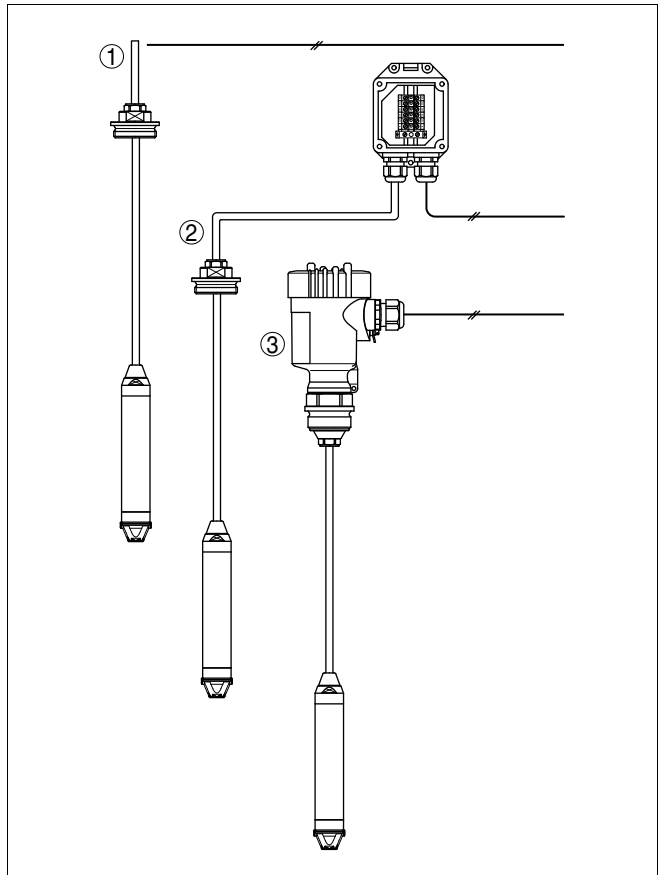

Fig. 6: Connect VEGAWELL 52 to power supply

- 1 Direct connection
- 2 Connection via VEGABOX 02
- 3 Connection via housing

Cable screening and grounding

If screened cable is necessary, connect the cable screen on both ends to ground potential. In the plastic housing, in VEGABOX 02 or in VEGADIS 12, the screen must be connected directly to the internal ground terminal. The ground terminal outside on the housing must be connected to the potential equalisation.

If potential equalisation currents are expected, the connection on the processing side must be made via a ceramic capacitor (e. g. 1 nF, 1500 V). The low frequency potential equalisation currents are thus suppressed, but the protective effect against high frequency interference signals remains.

Select connection cable for Ex applications



Take note of the corresponding installation regulations for Ex applications.

5.2 Connection procedure

Direct connection

Proceed as follows:

- 1 Wire the connection cable up to the connection compartment. The bending radius must be at least 25 mm.³⁾
- 2 Connect the wire ends to the screw terminals according to the wiring plan

Connection via VEGABOX 02

Proceed as follows:

- 1 Snap VEGABOX 02 onto the carrier rail or screw it to the mounting plate
- 2 Loosen the cover screws and remove the cover
- 3 Push the cable into VEGABOX 02 through the cable entry
- 4 Loosen the screws with a screwdriver
- 5 Insert the wire ends into the open terminals according to the wiring plan
- 6 Tighten the screws with a screwdriver
- 7 Check the hold of the wires in the terminals by lightly pulling on them
- 8 Tighten the compression nut of the cable entry. The seal ring must completely encircle the cable
- 9 Connect the supply cable according to steps 3 to 8
- 10 Screw the housing cover on

The electrical connection is finished.

Via the housing

Proceed as follows:

- 1 Unscrew the housing cover
- 2 Insert the connection cable through the cable entry into the plastic housing
- 3 Loosen the screws with a screwdriver
- 4 Insert the wire ends into the open terminals according to the wiring plan
- 5 Tighten the screws with a screwdriver

³⁾ The connection cable is already preconfecteded. After shortening the cable, fasten the type plate with support again to the cable.

- 6 Check the hold of the wires in the terminals by lightly pulling on them
 - 7 Tighten the compression nut of the cable entry. The seal ring must completely encircle the cable
 - 8 Retighten the housing cover
- The electrical connection is finished.

5.3 Wiring plan

Direct connection

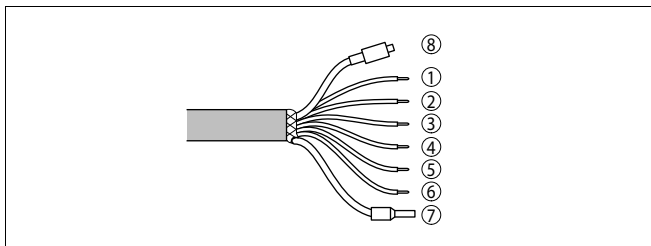

Fig. 7: Wire assignment, connection cable

- 1 Blue (-): to power supply or to the processing system
- 2 Brown (+): to power supply or to the processing system
- 3 White: for processing of the integrated Pt 100 (power supply)
- 4 Yellow: for processing of the integrated Pt 100 (measurement)
- 5 Red: for processing of the integrated Pt 100 (measurement)
- 6 Black: for processing of the integrated Pt 100 (power supply)
- 7 Shielding
- 8 Breather capillaries with filter element

Connection via VEGABOX 02

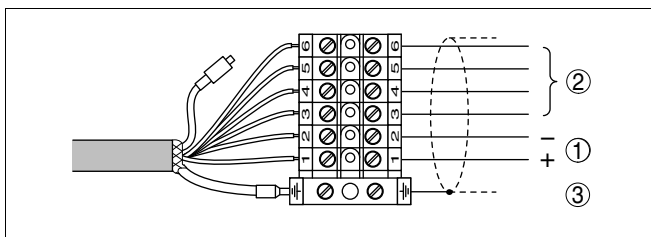

Fig. 8: Terminal assignment VEGABOX 02

- 1 To power supply or the processing system (signal pressure transmitter)
- 2 To power supply or the processing system (connection cables resistance thermometer Pt 100)
- 3 Shielding⁴⁾

Wire number	Wire colour/Polarity	Terminal VEGABOX 02
1	brown (+)	1
2	blue (-)	2
3	White	3

⁴⁾ Connect screen to ground terminal. Connect ground terminal on the outside of the housing as prescribed. The two terminals are galvanically connected.

Wire number	Wire colour/Polarity	Terminal VEGABOX 02
4	Yellow	4
5	Red	5
6	Black	6
	Shielding	Ground

**Connection via
VEGABOX 02 with inte-
grated transmitter for
Pt 100**

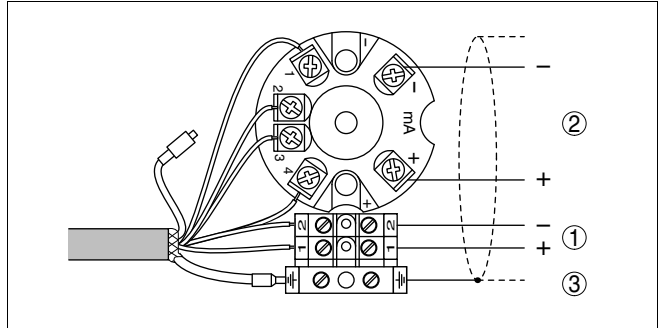

Fig. 9: Terminal assignment VEGABOX 02

- 1 To power supply or the processing system (signal pressure transmitter)
- 2 For voltage supply or to processing system (resistance thermometer Pt 100)
- 3 Shielding⁵⁾

Wire number	Wire colour/Polarity	Terminal VEGABOX 02
1	brown (+)	1
2	blue (-)	2
3	Shielding	Ground

Wire number	Wire colour/Polarity	Terminal temperature transmitter
3	White	1
4	Yellow	2
5	Red	3
6	Black	4

⁵⁾ Connect screen to ground terminal. Connect ground terminal on the outside of the housing as prescribed. The two terminals are galvanically connected.

Connection via housing

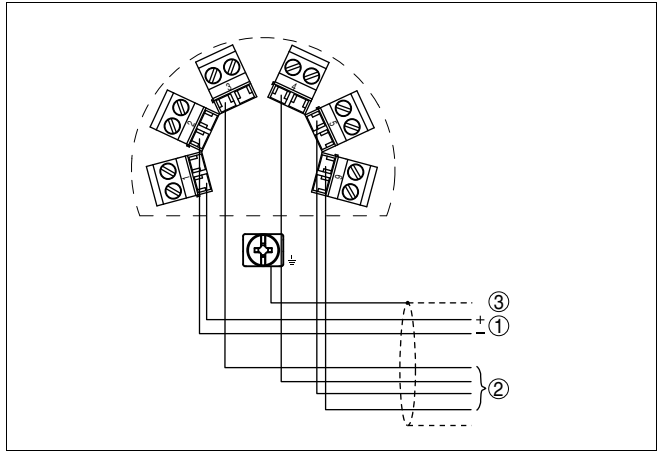

Fig. 10: Terminal assignment of the housing

- 1 To power supply or the processing system (signal pressure transmitter)
- 2 For voltage supply or to processing system (resistance thermometer Pt 100)
- 3 Shielding⁶⁾

Terminal number	Wire colour transmitter/polarity	Function
1	brown (+)	Power supply/signal pressure transmitter
2	blue (-)	Power supply/signal pressure transmitter
3	White	Power supply Pt 100
4	Yellow	Measurement Pt 100
5	Red	Measurement Pt 100
6	Black	Power supply Pt 100

5.4 Switch on phase

After connecting VEGAWELL 52 to power supply or after a voltage recurrence, the instrument carries out a self-check:

- Internal check of the electronics
- 4 ... 20 mA output jumps to the failure signal

The instrument delivers after this run-up period a current of 4 ... 20 mA to the cable. The value corresponds to the actual level as well as to settings already carried out, e.g. the factory setting.

⁶⁾ Connect screen to ground terminal. Connect ground terminal on the outside of the housing as prescribed. The two terminals are galvanically connected.

6 Setup with PACTware

6.1 Connecting the PC

Connecting the PC to the signal cable

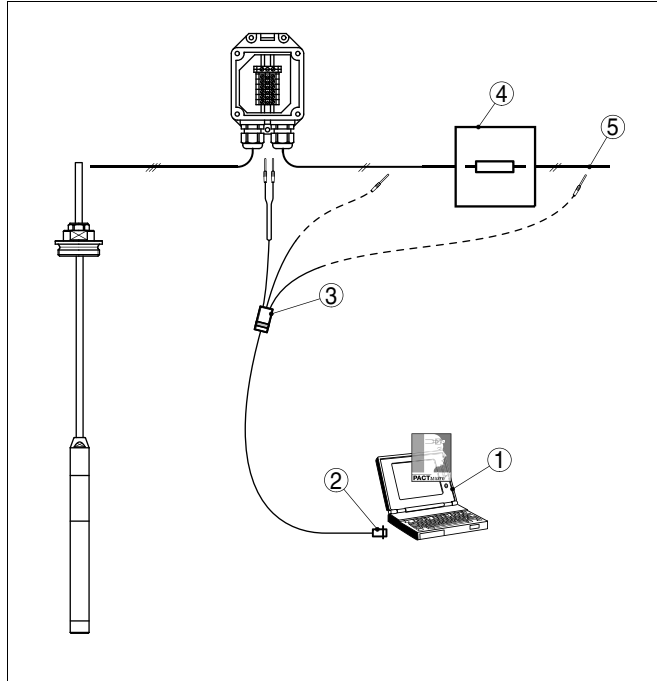

Fig. 11: Connection of the PC to VEGABOX 02 or communication resistor

- 1 PC with PACTware
- 2 RS232 interface (with VEGACONNECT 3), USB interface (with VEGACONNECT 4)
- 3 VEGACONNECT 3 or 4
- 4 Communication resistor 250 Ω
- 5 Power supply unit

Necessary components:

- VEGAWELL 52
- PC with PACTware and suitable VEGA DTM
- VEGACONNECT with HART adapter cable
- HART resistor approx. 250 Ω
- Power supply unit

**Note:**

With power supply units with integrated HART resistance (internal resistance approx. 250 Ω), an additional external resistance is not necessary (e. g. VEGATRENN 149A, VEGADIS 371, VEGAMET 381/624/625, VEGASCAN 693). In such cases, VEGACONNECT can be connected parallel to the 4 ... 20 mA cable.

6.2 Parameter adjustment with PACTware

Further setup steps are described in the operating instructions manual "*DTM Collection/PACTware*" attached to each CD and which can also be downloaded from our homepage. A detailed description is available in the online help of PACTware and the VEGA DTMs.

**Note:**

Keep in mind that for setup of VEGAWELL 52, DTM-Collection in the actual version must be used.

All currently available VEGA DTMs are provided in the DTM Collection on CD and can be obtained from the responsible VEGA agency for a token fee. This CD includes also the up-to-date PACTware version. The basic version of this DTM Collection incl. PACTware is also available as a free-of-charge download from the Internet.

Go via www.vega.com and "*Downloads*" to the item "*Software*".

6.3 Saving the parameter adjustment data

It is recommended to document or save the parameter adjustment data. They are hence available for multiple use or service purposes.

The VEGA DTM Collection and PACTware in the licensed, professional version provide suitable tools for systematic project documentation and storage.

7 Maintenance and fault rectification

7.1 Maintain

Maintenance

When used in the correct way, no special maintenance is required in normal operation.

In some applications, product buildup on the sensor diaphragm can influence the measuring result. Depending on the sensor and application, take precautions to ensure that heavy buildup, and especially a hardening thereof, is avoided.

Cleaning

If necessary, clean the transmitter. Make sure that the materials are resistant against the cleanig, see resistance list under "Services" on "www.vega.com". The application variety of VEGAWELL 52 requires special cleaning instructions for each application. Please ask the VEGA agency serving you.

7.2 Remove interferences

Reaction when malfunctions occur

The operator of the system is responsible for taken suitable measures to remove interferences.

Causes of malfunction

A maximum of reliability is ensured. Nevertheless, faults can occur during operation. These may be caused by the following, e.g.:

- Sensor
- Process
- Power supply
- Signal processing

Fault rectification

The first measures to be taken are to check the output signals as well as to evaluate the error messages via the indicating and adjustment module. The procedure is described below. Further comprehensive diagnostics can be carried out on a PC with the software PACTware and the suitable DTM. In many cases, the causes can be determined in this way and faults can be rectified.

24 hour service hotline

However, should these measures not be successful, call the VEGA service hotline in urgent cases under the phone no. **+49 1805 858550**.

The hotline is available to you 7 days a week round-the-clock. Since we offer this service world-wide, the support is only available in the English language. The service is free of charge, only the standard telephone costs will be charged.

Checking the 4 ... 20 mA signal

Connect a handheld multimeter in the suitable measuring range according to the wiring plan.

- ? 4 ... 20 mA signal not stable
- Level fluctuations
- Adjust integration time via PACTware

- no atmospheric pressure compensation
 - Check the capillaries and cut them clean
 - Check the pressure compensation in the housing and clean the filter element, if necessary
- ? 4 ... 20 mA signal missing
 - Wrong connection to power supply
 - Check connection according to chapter "*Connection steps*" and if necessary, correct according to chapter "*Wiring plan*"
 - No power supply
 - Check cables for breaks; repair if necessary
 - Operating voltage too low or load resistance too high
 - Check, adapt if necessary
- ? Current signal 3.6 mA; 22 mA
 - electronics module or measuring cell defective
 - Exchange instrument or return instrument for repair



In Ex applications, the regulations for the wiring of intrinsically safe circuits must be observed.

Reaction after fault rectification

Depending on the failure reason and measures taken, the steps described in chapter "*Set up*" must be carried out again, if necessary.

7.3 Shortening the suspension cable

Shorten the suspension cable individually. Proceed as follows:

- 1 Remove the filter adapter from the transparent capillary line
- 2 Cut the suspension cable with an edge cutter to the requested length



Caution:

Do not squeeze the capillary cable, this will influence the pressure compensation. If necessary, rework with a sharp knife.

- 3 Remove approx. 10 cm of the cable mantle, strip off approx. 1 cm of the wire ends

Insert the filter adapter

The work steps are finished.

7.4 Shortening the suspension cable

The suspension cable can be shortened individually. For the version with plastic or stainless steel housing proceed as follows:

- 1 Unscrew the housing cover

- 2 Loosen the screw terminals and remove the wire ends of the suspension cable out of the screw terminals
- 3 Hold the hexagon on the screwed socket with SW 46 and loosen with seal screw SW 22

**Caution:**

Seal screw is secured with Loctide pink, note breakaway torque!

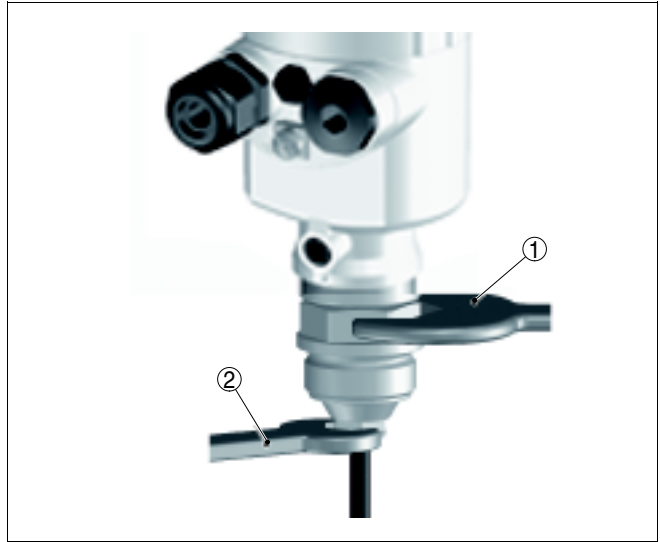

Fig. 12: Step 4

- 1 SW 46
- 2 SW 22

- 4 Pull the suspension cable out of the screwed socket, remove the pressure screw, cone sleeve and seal cone from the cable
- 5 Remove the filter adapter from the transparent capillary line

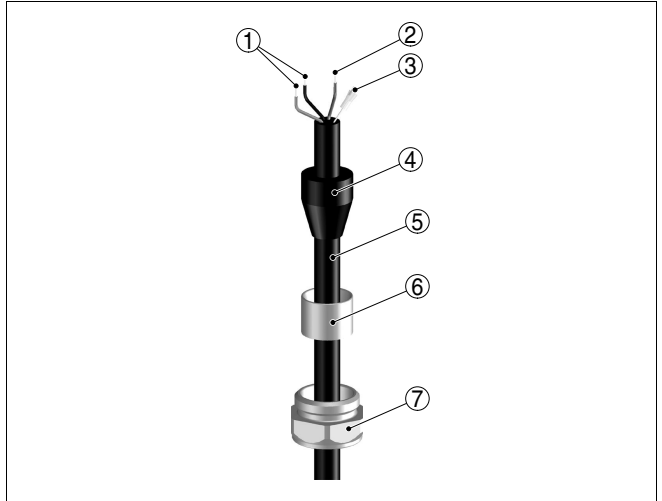

Fig. 13: Configuration of the cable seal

- 1 Connection cable (up to 6 pieces depending on the version)
- 2 Cable screen
- 3 Breather capillaries with filter element
- 4 Seal cone
- 5 Suspension cable
- 6 Cone bushing
- 7 Seal screw

- 6 Cut the suspension cable with an edge cutter to the requested length
- 7 Remove approx. 10 cm of the cable mantle, strip off approx. 1 cm of the wire ends, insert the filter adapter
- 8 Shift the seal screw, cone sleeve and seal cone to the suspension cable and insert the cable into the screwed socket, insert the wire ends through the cable entry into the mounting plate

The work steps are finished.

7.5 Instrument repair

If a repair is necessary, please proceed as follows:

You can download a return form (23 KB) from our Internet homepage www.vega.com under: "Downloads - Forms and certificates - Repair form".

By doing this you help us carry out the repair quickly and without having to call back for needed information.

- Print and fill out one form per instrument
- Clean the instrument and pack it damage-proof

- Attach the completed form and, if need be, also a safety data sheet outside on the packaging
- Please ask the agency serving you for the address of your return shipment. You can find the respective agency on our website www.vega.com under: "*Company - VEGA worldwide*"

8 Dismounting

8.1 Dismounting steps

**Warning:**

Before dismounting, be aware of dangerous process conditions such as e.g. pressure in the vessel, high temperatures, corrosive or toxic products etc.

Take note of chapters "*Mounting*" and "*Connecting to power supply*" and carry out the listed steps in reverse order.

8.2 Disposal

The instrument consists of materials which can be recycled by specialised recycling companies. We use recyclable materials and have designed the electronics to be easily separable.

WEEE directive 2002/96/EG

This instrument is not subject to the WEEE directive 2002/96/EG and the respective national laws. Pass the instrument directly on to a specialised recycling company and do not use the municipal collecting points. These may be used only for privately used products according to the WEEE directive.

Correct disposal avoids negative effects to persons and environment and ensures recycling of useful raw materials.

Materials: see chapter "*Technical data*"

If you have no possibility to dispose of the old instrument professionally, please contact us concerning return and disposal.

9 Supplement

9.1 Technical data

General data

Measured value	Level
Measuring principle	Ceramic-capacitive, dry measuring cell
Communication interface	HART signal on 4 ... 20 mA cable

Materials and weights

Materials, wetted parts

– Transmitter	316L, 316L with PE coating, 1.4462 (Duplex), 1.4462 with PE coating, PVDF, Titanium
– Protective cap	PA, PE
– Diaphragm	sapphire ceramic® (99.9 % oxide ceramic)
– Joining material diaphragm/Basic element measuring cell	Glass solder
– Measuring cell seal	FKM (VP2/A) - FDA and KTW approved, FFKM (Perlast G75S), EPDM (A+P 75.5/KW75F)
– Suspension cable	PE (FDA and KTW-approved), FEP, PUR
– Cable gland on the transmitter	316L
– Cable seal with PE, PUR cable	FKM
– Cable seal with FEP cable	FEP
– Process fitting	316L
– Straining clamp	1.4301
– Unassembled screw connection	316L, PVDF
– Threaded connection on the housing	316L

Materials, non-wetted parts

– Housing	plastic PBT (Polyester), 316L
– type label support on cable	PE hard
– transport protection net	PE

Weight approx.

– Basic weight	0.8 kg (1.764 lbs)
– Suspension cable	0.1 kg/m (0.07 lbs/ft)
– Straining clamp	0.2 kg (0.441 lbs)
– Screw connection	0.4 kg (0.882 lbs)
– Plastic housing	0.8 kg (1.764 lbs)
– Stainless steel housing	1.6 kg (3.528 lbs)

Input variable

percentage value	-10 ... +110 % of the nominal measuring range
------------------	---

pressure value -20 ... +120 % of the nominal measuring range

Recommended max. turn down 10 : 1 (no limitation)

Nominal measuring ranges and overload capability in bar/kPa

Nominal range	Overload, max. pressure	Overload, min. pressure
Gauge pressure		
0 ... 0.1 bar/0 ... 10 kPa	15 bar/1500 kPa	-0.2 bar/-20 kPa
0 ... 0.2 bar/0 ... 20 kPa	20 bar/2000 kPa	-0.4 bar/-40 kPa
0 ... 0.4 bar/0 ... 40 kPa	30 bar/3000 kPa	-0.8 bar/-80 kPa
0 ... 1 bar/0 ... 100 kPa	35 bar/3500 kPa	-1 bar/-100 kPa
0 ... 2.5 bar/0 ... 250 kPa	50 bar/5000 kPa	-1 bar/-100 kPa
0 ... 5 bar/0 ... 500 kPa	65 bar/6500 kPa	-1 bar/-100 kPa
0 ... 10 bar/0 ... 1000 kPa	90 bar/9000 kPa	-1 bar/-100 kPa
0 ... 25 bar/0 ... 2500 kPa	130 bar/13000 kPa	-1 bar/-100 kPa
Absolute pressure		
0 ... 1 bar/0 ... 100 kPa	35 bar/3500 kPa	0 bar abs.
0 ... 2.5 bar/0 ... 250 kPa	50 bar/5000 kPa	0 bar abs.
0 ... 5 bar/0 ... 500 kPa	65 bar/6500 kPa	0 bar abs.
0 ... 10 bar/0 ... 1000 kPa	90 bar/9000 kPa	0 bar abs.
0 ... 25 bar/0 ... 2500 kPa	130 bar/13000 kPa	0 bar abs.

Nominal measuring ranges and overload capability in psig

Nominal range	Overload, max. pressure	Overload, min. pressure
Gauge pressure		
0 ... 1.5 psig	200 psig	-3 psig
0 ... 3 psig	290 psig	-6 psig
0 ... 6 psig	430 psig	-12 psig
0 ... 15 psig	500 psig	-15 psig
0 ... 35 psig	700 psig	-15 psig
0 ... 70 psig	950 psig	-15 psig
0 ... 150 psig	1300 psig	-15 psig
0 ... 350 psig	1900 psig	-15 psig
0 ... 900 psig	2900 psig	-15 psig
Absolute pressure		
0 ... 15 psi	500 psi	0 psi
0 ... 35 psi	700 psi	0 psi
0 ... 70 psi	900 psi	0 psi
0 ... 150 psi	1300 psi	0 psi
0 ... 350 psi	1900 psi	0 psi

Output variable

Output signal	4 ... 20 mA/HART
Signal resolution	2 μ A
Failure signal	< 3.6 mA; 20.5 mA; 22 mA; unchanged (adjustable via PACTware)
Max. output current	22 mA
Run-up time approx.	15 s
Step response time	\leq 200 ms (ti: 0 s, 0 ... 63 %)
Fulfilled NAMUR recommendations	NE 43

Additional output parameter - temperature

integrated resistance thermometer	Pt 100 according to DIN EN 60751
Range	-50 ... +100 °C (-58 ... +212 °F)
Resolution	1 °K

Reference conditions and actuating variables (similar to DIN EN 60770-1)

Reference conditions according to DIN EN 61298-1

– Temperature	+15 ... +25 °C (+59 ... +77 °F)
– Relative humidity	45 ... 75 %
– Air pressure	860 ... 1060 mbar/86 ... 106 kPa (12.5 ... 15.4 psig)
Determination of characteristics	Limit point adjustment according to IEC 61298-2
Characteristics	linear
Reference installation position	upright, diaphragm points downward
Influence of the installation position	< 0.2 mbar/20 Pa (0.003 psig)

Deviation determined according to the limit point method according to IEC 60770⁷⁾

Applies to **digital** HART interface as well as to **analogue** current output 4 ... 20 mA. Specifications refer to the set span. Turn down (TD) is the relation nominal measuring range/set span.

Deviation with version < 0.25 %

– Turn down 1 : 1 up to 5 : 1	< 0.25 %
– Turn down up to 10 : 1	< 0.05 % x TD

Deviation with version < 0.1 %

– Turn down 1 : 1 up to 5 : 1	< 0.1 %
– Turn down up to 10 : 1	< 0.02 % x TD

Influence of the product or ambient temperature

Applies to **digital** HART interface as well as to **analogue** current output 4 ... 20 mA. Specifications refer to the set span. Turn down (TD) is the relation nominal measuring range/set span.

⁷⁾ Incl. non-linearity, hysteresis and non-repeatability.

Average temperature coefficient of the zero signal

In the compensated temperature range of 0 ... +80 °C (+32 ... +176 °F), reference temperature 20 °C (68 °F).

Average temperature coefficient of the zero signal

- Turn down 1 : 1 < 0.15 %/10 K
- Turn down up to 5 : 1 < 0.2 %/10 K
- Turn down up to 10 : 1 < 0.25 %/10 K

Outside the compensated temperature range:

Average temperature coefficient of the zero signal

- Turn down 1 : 1 typ. < 0.15 %/10 K

Long-term stability (similar to DIN 16086, DINV 19259-1 and IEC 60770-1)

Applies to **digital** HART interface as well as to **analogue** current output 4 ... 20 mA. Specifications refer to the set span. Turn down (TD) is the relation nominal measuring range/set span.

Long-term drift of the zero signal < (0.1 % x TD)/year

Total deviation (similar to DIN 16086)

The total deviation F_t , also called practical deviation, is the sum of the basic accuracy F_p and long-term stability:

$$F_t = F_p + F_s$$

$$F_{\text{perf}} = \sqrt{(F_T)^2 + (F_{Kl})^2}$$

With

- F_t : F_{total} , total deviation
- F_p : F_{perf} , basic accuracy
- F_s : F_{stab} , long-term drift
- F_T : Temperature coefficient (influence of medium or ambient temperature)
- F_{Kl} : Deviation

Ambient conditions

Ambient temperature

- Connection cable PE -40 ... +60 °C (-40 ... +140 °F)
- Connection cable PUR, FEP -40 ... +80 °C (-40 ... +176 °F)

Storage and transport temperature

-40 ... +80 °C (-40 ... +176 °F)

Process conditions

Max. process pressure, transmitter⁸⁾

⁸⁾ Limited by the overpressure resistance of the measuring cell.

Load

see diagram

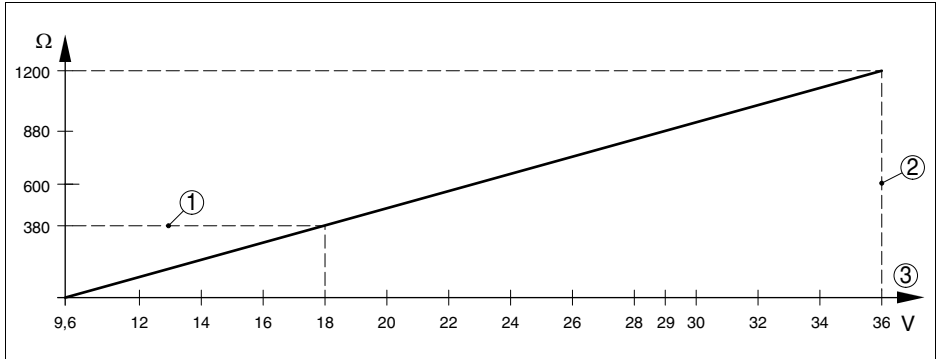

Fig. 14: Voltage diagram

- 1 HART load
- 2 Voltage limit
- 3 Operating voltage

Integrated overvoltage protection

Nominal leakage current (8/20 μ s)	5 kA
Min. response time	< 25 ns

Electrical protective measures

Protection	
- Transmitter	IP 68 (30 bar)
- Housing	IP 66/IP 67
Overvoltage category	III
Protection class	III

Approvals

Depending on the version, instruments with approvals can have different technical data.

For these instruments, the corresponding approval documents have to be taken into account. These are part of the delivery or can be downloaded under www.vega.com via "VEGA Tools" and "serial number search" as well as via "Downloads" and "Approvals".

9.2 Dimensions

VEGAWELL 52 - suspension cable 1

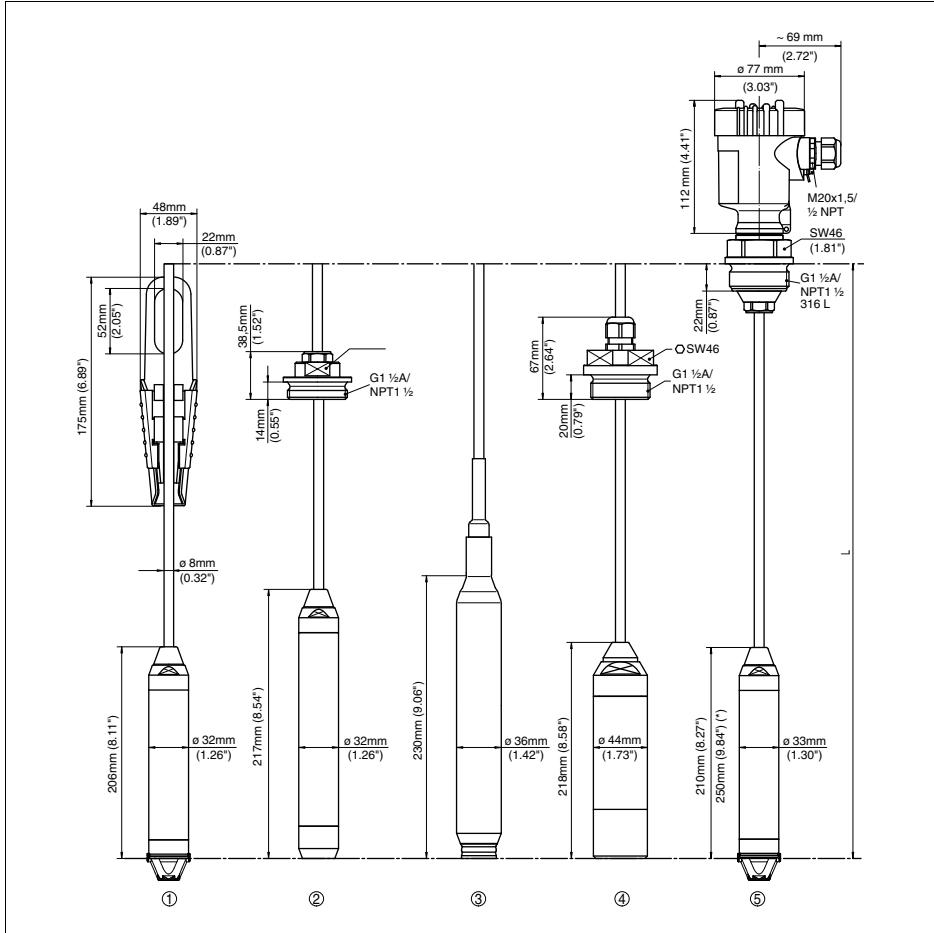

Fig. 15: VEGAWELL 52 - suspension cable

- 1 Transmitter Duplex, with straining clamp
- 2 Transmitter Duplex for deep wells, with unassembled screw connection G1 1/2 A (1 1/2 NPT) and closing cap
- 3 Transmitter Duplex, with PE coating
- 4 Transmitter with screwed connection of PVDF
- 5 Transmitter Titanium/Titanium with glass leadthrough, with thread G1 A (1 NPT) and plastic housing

VEGAWELL 52 - threaded fitting

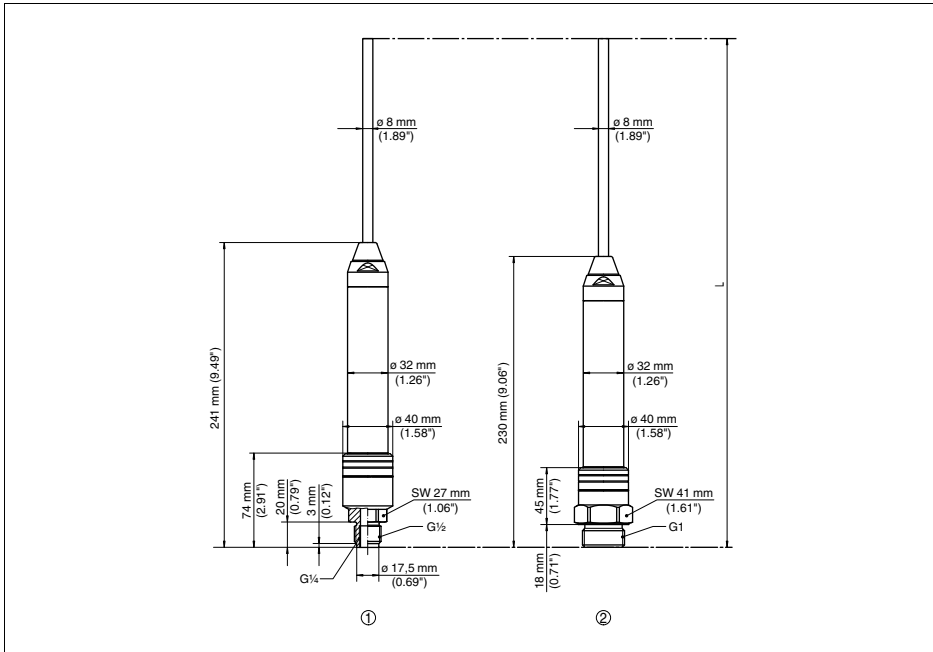

Fig. 17: VEGAWELL 52 - thread

- 1 Threaded fitting $G\frac{1}{2}$ inner $G\frac{1}{4}$
- 2 Threaded fitting $G1$

9.3 Industrial property rights

VEGA product lines are global protected by industrial property rights. Further information see <http://www.vega.com>.

Only in U.S.A.: Further information see patent label at the sensor housing.

VEGA Produktfamilien sind weltweit geschützt durch gewerbliche Schutzrechte.

Nähere Informationen unter <http://www.vega.com>.

Les lignes de produits VEGA sont globalement protégées par des droits de propriété intellectuelle. Pour plus d'informations, on pourra se référer au site <http://www.vega.com>.

VEGA líneas de productos están protegidas por los derechos en el campo de la propiedad industrial. Para mayor información revise la pagina web <http://www.vega.com>.

Линии продукции фирмы ВЕГА защищаются по всему миру правами на интеллектуальную собственность. Дальнейшую информацию смотрите на сайте <http://www.vega.com>.

VEGA系列产品在全球享有知识产权保护。
进一步信息请参见网站<<http://www.vega.com>>。

9.4 Trademark

All brands used as well as trade and company names are property of their lawful proprietor/originator.



Printing date:

VEGA Grieshaber KG
Am Hohenstein 113
77761 Schiltach
Germany
Phone +49 7836 50-0
Fax +49 7836 50-201
E-mail: info@de.vega.com
www.vega.com



All statements concerning scope of delivery, application, practical use and operating conditions of the sensors and processing systems correspond to the information available at the time of printing.

© VEGA Grieshaber KG, Schiltach/Germany 2009