

Flow sensors

SD9000

SDR32DGXFPKG/US
Compressed air meter
Plug and socket
Process connection: R1½ (DN40)

Function programmable
2 outputs
OUT1 = flow monitoring (binary), flow rate meter (pulse), preset meter (binary)
OUT2 = flow monitoring (analogue or binary)
Monitoring range
0...492 Nm³/h
Measuring range
1.3 (1.5)...410 Nm³/h *)
Temperature indication
0...60 °C

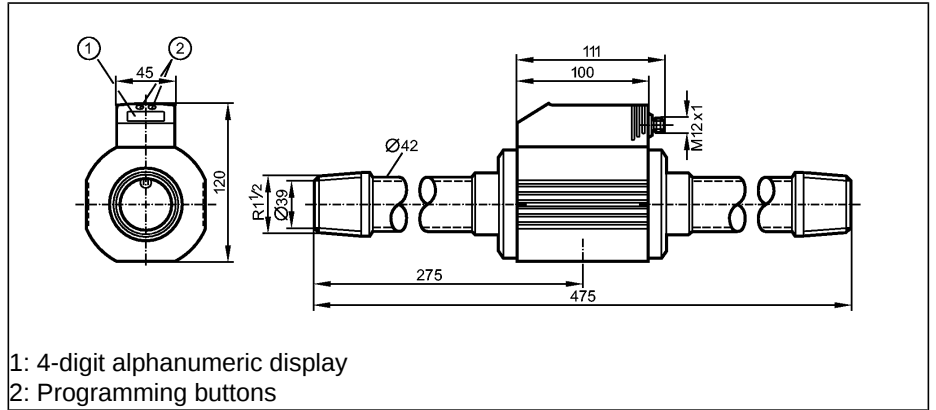

Made in Germany



Application
Electrical design
Output

Compressed air
Air quality(DIN 8573-1):
Class 141 (measuring error: see below, value A)
Class 344 (measuring error: see below, value B)
DC PNP
OUT1: normally open / closed programmable or pulse
OUT2: normally open / closed programmable or analogue (4...20 mA scaleable)

Operating voltage	[V]
Current rating	[mA]
Short-circuit protection	
Reverse polarity protection	
Overload protection	
Voltage drop	[V]
Current consumption	[mA]
Power-on delay time	[s]
Analogue output	
Pulse output	
Pulse value / setting in steps of [m³]	
Pulse length [s]	
Programming options	

19...30 DC 1)
2 x 250
pulsed
yes
yes
< 2
< 100
0.5
4...20 mA (< 500 Ω)
consumed quantity meter
0.005...4 000 000 / 0.001...1000
min. 0.037 / max. 2
hysteresis / window function; NO / NC; current / pulse output; display can be rotated / deactivated; display unit

Flow monitoring	
Display range	0.0...492.0 Nm³/h
Measuring range	1.3 (1.5)...410.0 *) Nm³/h
Setting range	
Set point, SP	3.5...410.0 Nm³/h
Reset point, rP	1.5...408.0 Nm³/h
Analogue start point, ASP	0.0...307.5 Nm³/h
Analogue end point, AEP	102.5...410.0 Nm³/h
in steps of	0.5 Nm³/h
Damping, dAP	[s]
Response time	[s]
Accuracy [% of the final value]	
Measuring dynamics	
Temperature monitoring	
Display range	0.0...60.0
Measuring range	0.0...60.0
Accuracy	[°C] ± 2 **)

0...8200 NI/min NI/min
22.2 (30)...6830 *) NI/min
60...6830 NI/min
30...6800 NI/min
0...5120 NI/min
1710...6830 NI/min
10 NI/min
0 - 0.2 - 0.4 - 0.6 - 0.8 - 1
< 0.1 (dAP = 0)
A): ± (3% MW + 0.3% MEW) / B): ± (6% MW + 0.6% MEW)
1:300
0.0...60.0
0.0...60.0
± 2 **)

SD9000

Max. relative air humidity [%]	90
Ambient temperature [°C]	0...60
Medium temperature [°C]	0...60
Storage temperature [°C]	-20...85
Protection	IP 65, III
Pressure rating [bar]	16
Vibration resistance	DIN IEC 68-2-6:5 g (55...2000 Hz)
EMC	EN 61000-4-2 ESD: 4 kV CD / 8 kV AD EN 61000-4-3 HF radiated: 10 V/m EN 61000-4-4 Burst: 2 kV EN 61000-4-6 HF conducted: 10 V
Housing materials	PBT-GF 20; PC (APEC); Makrolon; stainless steel (304S15); Viton
Materials (wetted parts)	stainless steel 316 / 1.4401; stainless steel (304S15); ceramics; glass passivated; PEEK (polyether ether ketone); polyester; Viton; aluminium; anodised
Display	Display unit 4 x LED green (NI/min, Nm ³ /h, Nm ³ , °C) Function display 1 x LED yellow Switching status 2 x LED yellow Measured values 4-digit alphanumeric display Programming 4-digit alphanumeric display
Connection	M12 connector
Weight [kg]	4.154
Remarks	1) to EN50178, SELV, PELV; referring to UL: "limited voltage" with overcurrent protection in accordance with UL508 *) in brackets: displayed value **) medium flow in the limit area of the flow measurement range MW = measured value MEW = final value of the measuring range Measuring, display and setting ranges refer to standard volume flow according to DIN ISO 2533. For information about installation and operation please see the operating instructions.

Wiring

Programming of the output function

-----OUT1-----

- Switching output
- Hno = hysteresis / normally open
- Hnc = hysteresis / normally closed
- Fno = window function / normally open
- Fnc = window function / normally closed
- ImP = pulse output for flow rate meter / signal output for preset meter

-----OUT2-----

- Switching output
- Hno = hysteresis / normally open
- Hnc = hysteresis / normally closed
- Fno = window function / normally open
- Fnc = window function / normally closed
- Analogue output
- I = current output (4...20 mA)

