

Operating Instructions

Indicating and adjustment module PLICSCOM



Document ID:
36433

Indication
and adjustment

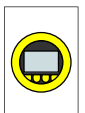

Contents

1	About this document	
1.1	Function	4
1.2	Target group	4
1.3	Symbolism used	4
2	For your safety	
2.1	Authorised personnel	5
2.2	Appropriate use	5
2.3	Warning about misuse	5
2.4	General safety instructions	5
2.5	CE conformity	6
2.6	Fulfillment of NAMUR recommendations	6
2.7	Environmental instructions	6
3	Product description	
3.1	Configuration	7
3.2	Principle of operation	7
3.3	Packaging, transport and storage	8
4	Prepare setup	
4.1	Insert indicating and adjustment module	9
4.2	Adjustment system	10
5	Set up - Sensors up to SW 3.99	
5.1	Adjustment menu for all signal outputs	11
5.2	Adjustment menu 4 ... 20 mA/HART	18
5.3	Adjustment menu Profibus PA	21
6	Set up - Sensors from HW 2.0.0 and SW 4.0.0	
6.1	Adjustment menu for all signal outputs	24
6.2	Adjustment menu 4 ... 20 mA/HART	30
7	Maintenance and fault rectification	
7.1	Maintenance	32
7.2	How to proceed in case of repair	32
8	Dismount	
8.1	Dismounting steps	33
8.2	Disposal	33
9	Supplement	
9.1	Technical data	34
9.2	Dimensions	35

**Safety instructions for Ex areas**

Please note the Ex-specific safety information for installation and operation in Ex areas. These safety instructions are part of the operating instructions manual and come with the Ex-approved instruments.

1 About this document

1.1 Function

This operating instructions manual provides all the information you need for mounting, connection and setup as well as important instructions for maintenance and fault rectification. Please read this information before putting the instrument into operation and keep this manual accessible in the immediate vicinity of the device.

1.2 Target group

This operating instructions manual is directed to trained qualified personnel. The contents of this manual should be made available to these personnel and put into practice by them.

1.3 Symbolism used



Information, tip, note

This symbol indicates helpful additional information.



Caution: If this warning is ignored, faults or malfunctions can result.

Warning: If this warning is ignored, injury to persons and/or serious damage to the instrument can result.

Danger: If this warning is ignored, serious injury to persons and/or destruction of the instrument can result.



Ex applications

This symbol indicates special instructions for Ex applications.



List

The dot set in front indicates a list with no implied sequence.



Action

This arrow indicates a single action.



Sequence

Numbers set in front indicate successive steps in a procedure.

2 For your safety

2.1 Authorised personnel

All operations described in this operating instructions manual must be carried out only by trained specialist personnel authorised by the plant operator.

During work on and with the device the required personal protective equipment must always be worn.

2.2 Appropriate use

The pluggable indicating and adjustment module is used for measured value indication, adjustment and diagnoses with level and pressure sensors.

You can find detailed information on the application range in chapter "*Product description*".

Operational reliability is ensured only if the instrument is properly used according to the specifications in the operating instructions manual as well as possible supplementary instructions.

2.3 Warning about misuse

Inappropriate or incorrect use of the instrument can give rise to application-specific hazards, e.g. vessel overfill or damage to system components through incorrect mounting or adjustment.

2.4 General safety instructions

This is a state-of-the-art instrument that fulfils the prevailing regulations and guidelines. The instrument must only be operated in a technically flawless and reliable condition. The operator is responsible for the trouble-free operation of the instrument.

During the entire duration of use, the user is obliged to determine the compliance of the required occupational safety measures with the current valid rules and regulations and also take note of new regulations.

The safety instructions in this operating instructions manual, the national installation standards as well as the valid safety regulations and accident prevention rules must be observed by the user.

For safety and warranty reasons, any invasive work on the device beyond that described in the operating instructions manual may be carried out only by personnel authorised by the manufacturer. Arbitrary conversions or modifications are explicitly forbidden.

The safety approval markings and safety tips on the device must be also observed.

2.5 CE conformity

The device fulfills the legal requirements of the applicable EC guidelines. By attaching the CE mark, VEGA provides a confirmation of successful testing. You can find the CE conformity declaration in the download area of www.vega.com.

2.6 Fulfillment of NAMUR recommendations

The requirements of the following NAMUR recommendations are fulfilled:

- NE 21 - "Electromagnetic Compatibility Act of the process and laboratory control technology"

The sensors as well as the corresponding indicating and adjustment components are generally upward and downward compatible.

2.7 Environmental instructions

Protection of the environment is one of our most important duties. That is why we have introduced an environment management system with the goal of continuously improving company environmental protection. The environment management system is certified according to DIN EN ISO 14001.

Please help us fulfil this obligation by observing the environmental instructions in this manual:

- Chapter "*Packaging, transport and storage*"
- Chapter "*Disposal*"

3 Product description

3.1 Configuration

Scope of the operating instructions manual

This operating instructions manual applies to the following hardware and software versions of the indicating and adjustment module:

- Hardware from 1.0.0
- Software from 1.0.0

Instrument versions

The indicating/adjustment module consists of a display with full dot matrix as well as four keys for adjustment.

A background lighting is optionally integrated and can be adjusted via the adjustment menu.

The display can be optionally equipped with heating to ensure good readability at low temperatures down to -40 °C (-40 °F).

Scope of delivery

The scope of delivery encompasses:

- Indicating and adjustment module
- Documentation
 - this operating instructions manual
 - Supplementary instructions manual 31708 "*Heating for indicating and adjustment module*" (optional)

3.2 Principle of operation

Application area

The indicating and adjustment module is used for measured value indication, adjustment, and diagnostics for the following VEGA plics[®] sensors:

- VEGAPULS series 60
- VEGAFLEX series 60
- VEGASON series 60
- VEGABAR series 50 and 60
- VEGACAL series 60

The indicating and adjustment module is mounted in the sensor housing. After installation, the sensor as well as the indicating and adjustment module are splash-proof, even without housing cover.

Another installation possibility is the external indicating and adjustment unit VEGADIS 61. The operation of two indicating and adjustment module in parallel in the sensor and in VEGADIS 61 however is not supported.

Functional range

The functional range of the indicating and adjustment module is determined by the sensor and corresponds to the respective software version of the sensor.

Power supply

Power is supplied directly by the respective sensor or by VEGADIS 61. An additional connection is not necessary.

The backlight is also powered by the sensor or via VEGADIS 61. Prerequisite for this is a supply voltage at a certain level. The exact voltage specifications can be found in the operating instructions manual of the respective sensor.

The optional heating requires its own power supply. You can find further details in the supplementary instructions manual "*Heating for indicating and adjustment module*".

3.3 Packaging, transport and storage

Packaging

Your instrument was protected by packaging during transport. Its capacity to handle normal loads during transport is assured by a test according to DIN EN 24180.

The packaging of standard instruments consists of environment-friendly, recyclable cardboard. For special versions, PE foam or PE foil is also used. Dispose of the packaging material via specialised recycling companies.

Transport

Transport must be carried out under consideration of the notes on the transport packaging. Nonobservance of these instructions can cause damage to the device.

Transport inspection

The delivery must be checked for completeness and possible transit damage immediately at receipt. Ascertained transit damage or concealed defects must be appropriately dealt with.

Storage

Up to the time of installation, the packages must be left closed and stored according to the orientation and storage markings on the outside.

Unless otherwise indicated, the packages must be stored only under the following conditions:

- Not in the open
- Dry and dust free
- Not exposed to corrosive media
- Protected against solar radiation
- Avoiding mechanical shock and vibration

Storage and transport temperature

- Storage and transport temperature see chapter "*Supplement - Technical data - Ambient conditions*"
- Relative humidity 20 ... 85 %

4 Prepare setup

4.1 Insert indicating and adjustment module

Mount/Dismount indicating and adjustment module

The indicating and adjustment module can be inserted into the sensor and removed again at any time. It is not necessary to interrupt the power supply.

Proceed as follows:

- 1 Unscrew the housing cover
- 2 Place the indicating and adjustment module in the desired position on the electronics (you can choose any one of four different positions - each displaced by 90°)
- 3 Press the indicating and adjustment module onto the electronics and turn it to the right until it snaps in.
- 4 Screw housing cover with inspection window tightly back on

Removal is carried out in reverse order.

The indicating and adjustment module is powered by the sensor, an additional connection is not necessary.

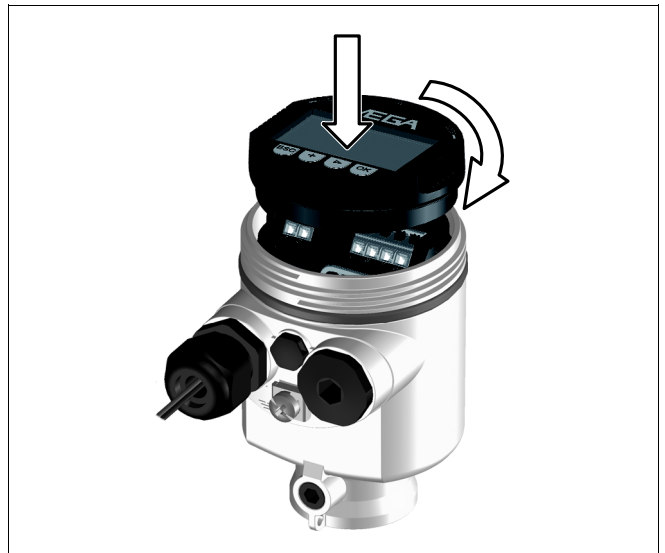

Fig. 1: Insert indicating and adjustment module



Note:

If you intend to retrofit the instrument with an indicating and adjustment module for continuous measured value indication, a higher cover with an inspection glass is required.

4.2 Adjustment system

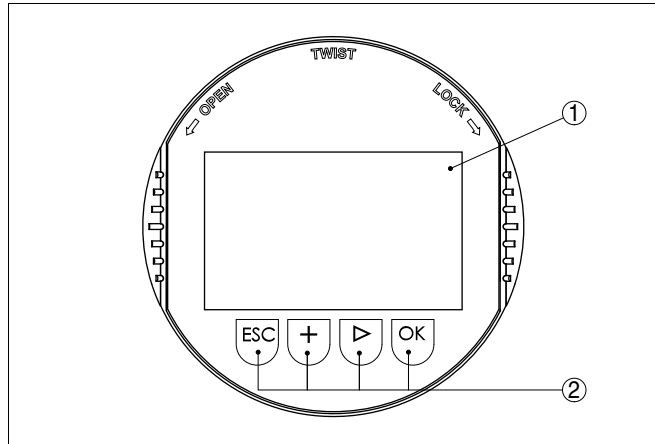

Fig. 2: Indicating and adjustment elements

- 1 LC display
- 2 Adjustment keys

Key functions

- **[OK]** key:
 - Move to the menu overview
 - Confirm selected menu
 - Edit parameter
 - Save value
- **[->]** key:
 - Presentation change measured value
 - list entry
 - Select editing position
- **[+]** key:
 - Change value of the parameter
- **[ESC]** key:
 - interrupt input
 - Jump to next higher menu

Adjustment system

The sensor is adjusted via the four keys of the indicating and adjustment module. The LC display indicates the individual menu items. The functions of the individual keys are shown in the above illustration. Approx. 10 minutes after the last pressing of a key, an automatic reset to measured value indication is triggered. Any values not confirmed with **[OK]** will not be saved.

5 Set up - Sensors up to SW 3.99

5.1 Adjustment menu for all signal outputs

With the parameter adjustment, the instrument is adapted to the application conditions. The parameter adjustment is carried out via an adjustment menu.



Information:

In this operating instructions, all general parameters are described. Additional instrument-specific parameters are described in the operating instructions of the respective sensor.

Measured value indication

The following presentations are available in the measured value display:

- Level as digital value, sensor TAG
- Level as digital value and bar graph, sensor TAG
- Only with pressure transmitters: Level or pressure as digital value, temperature value

With [**->**] you select the different presentations of the measured value. You can reach the menu overview from any presentation with [**OK**]. With [**ESC**] you return from the menu overview to the measured value display.

Main menu

The main menu is divided into five areas with the following functions:

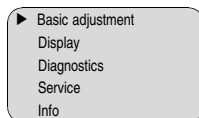

Basic adjustment/Damping

To damp process-dependent measured value fluctuations, you have to set an integration time of 0 ... 999 s in this menu item.

Depending on the sensor type, the factory setting is 0 s or 1 s.

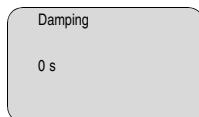

Basic adjustment/Linearization curve

In this menu item you select the linearization curve:

- linear
- Horizontal cylindrical tank
- Spherical tank

- User programmable

User programmable means: Switching on a linearization curve programmed via PC and PACTware

A linearization is necessary for all vessels in which the vessel volume does not increase linearly with the level - e. g. in a horizontal cylindrical or spherical tank - and the indication or output of the volume is required. Corresponding linearization curves are preprogrammed for these vessels. They represent the correlation between the level percentage and vessel volume. The linearisation applies to the measured value indication and the current output. By activating the appropriate curve, the volume percentage of the vessel is displayed correctly. If the volume should not be displayed in percent but e.g. in l or kg, a scaling can also be set in the menu item "Display".

Factory setting is linear.

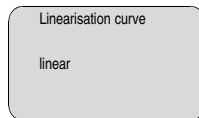

Caution:

Note the following, if the respective sensor is used as part of an overfill protection system according to WHG:

If a linearisation curve is selected, the measuring signal is no longer compulsorily linear proportional to the level. This must be taken into consideration by the user, particularly when adjusting the switching point on the level switch.

Basic adjustment/Sensor TAG

In the menu item "Sensor-TAG" you edit a 12-digit measurement loop name. An unambiguous designation can hence be assigned to the sensor, e.g. the measurement loop name or the tank or product designation. In digital systems and in the documentation of larger plants, a singular designation should be entered for exact identification of individual measuring sites.

The available digits comprise:

- Letters from A ... Z
- Numbers from 0 ... 9
- Special characters +, -, /, -

Factory setting is "Sensor".

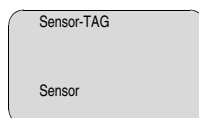

Display/Lighting

An integrated background lighting can be adjusted via the adjustment menu. The function depends on the height of the supply voltage, see operating instructions of the respective sensor.

In the default setting, the lightning is switched off.

Diagnosis/Pointer

Min. and max. measured values are saved in the sensor. The values are displayed in the menu item "Peak values".

- Min. and max. distance in m(d): Radar, guided microwave, ultrasonic sensors
- Min. and max. pressure: pressure transmitter¹⁾
- Min. and max. temperature: ultrasonic sensors, pressure transmitters

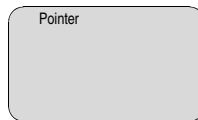

Diagnosis/Measurement reliability

When non-contact level sensors are used, the measurement can be influenced by the respective process conditions. In this menu item, the measurement reliability of the level echo is displayed as dB value. The measurement reliability equals signal strength minus noise. The higher the value, the more reliable the measurement. With a functioning measurement, the values are > 10 dB.

Diagnosis/Device status

In this menu item, the device status is displayed. If the sensor detects a fault, "OK" will be displayed. If a fault is detected, a flashing failure message is outputted sensor-specifically, e.g. "E013". The fault is also displayed in clear text, e.g. "No measurement value".



Information:

The fault message as well as the clear text indication are also carried out in the measured value display.

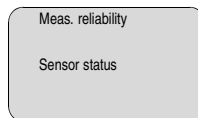

¹⁾ Pressure: -50 ... +150 % of the nominal pressure range; temperature: -50 ... +150 °C.

Diagnosis/Curve selection

With ultrasonic and radar sensors as well as sensors with guided microwave, the "**Echo curve**" represents the signal strength of the echoes over the measuring range. The units of the signal strength are "dB" (ultrasonic and radar) and "Volt" (guided microwave). The signal strength enables the assessment of the quality of the measurement.

With ultrasonic and radar sensors, the "**False echo curve**" represents the saved false echoes (see menu "*Service*") of the empty vessel with signal strength in "dB" over the measuring range.

Up to 3000 measured values are recorded (depending on the sensor) when starting a "**Trend curve**". Then the values can be displayed on a time axis. The oldest measured values are always deleted.

In the menu item "*Choose curve*", the respective curve is selected.

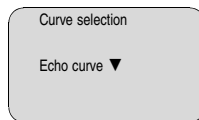

Information:

The trend recording is not activated when being shipped. It must be started by the user via the menu item "*Start trend curve*".

Diagnosis/Curve presentation

A comparison of echo and false echo curve allows a more detailed specification on the measurement reliability. The selected curve is updated permanently. With the **[OK]** key, a submenu with zoom functions is opened.

The following functions are available with "**Echo and false echo curve**":

- "X-Zoom": Zoom function for the meas. distance
- "Y-Zoom": 1, 2, 5 and 10-fold signal magnification in "dB"
- "Unzoom": Reset the presentation to the nominal measuring range with single magnification

In the menu item "**Trend curve**" the following are available:

- "X-Zoom": Resolution
 - 1 minute
 - 1 hour
 - 1 day
- "Stop/Start": Interrupt a recording or start a new recording
- "Unzoom": Reset the resolution to minutes

As default setting, the recording pattern has 1 minute. With the adjustment software PACTware, this pattern can be also set to 1 hour or 1 day.



Service/Simulation

In this menu item you simulate a user-defined level or pressure value via the current output. This allows you to test the signal path, e.g. through connected indicating instruments or the input card of the control system.

The following simulation variables are available:

- Percent
- Current
- Pressure (with pressure transmitters)
- Distance (with radar and guided microwave)

With Profibus PA sensors, the selection of the simulated value is made via the "Channel" in the menu "*Basic adjustments*".

How to start the simulation:

- 1 Push **[OK]**
- 2 Select the requested simulation variable with **[>]** and confirm with **[OK]**
- 3 Set the requested numerical value with **[+]** and **[>]**.
- 4 Push **[OK]**

The simulation is now running, with 4 ... 20 mA/HART a current is outputted and with Profibus PA or Foundation Fieldbus a digital value.

How to interrupt the simulation:

→ Push **[ESC]**



Information:

The simulation is terminated automatically 10 minutes after the last key has been pushed.

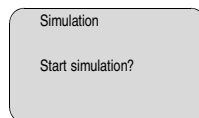

Service/Reset

With the reset function, modified values are reset. Three subfunctions are available:

- Basic adjustment
 - Reset the values modified with the indicating and adjustment module to the sensor-specific basic setting
- Factory setting

- As basic adjustment, but also reset of special parameters to the default values²⁾
- Peak values measured value and temperature³⁾
 - Reset of the min./max. values of pressure, level and temperature to the current values



Information:

Because the reset values are nearly sensor-specific, they are listed in the operating instructions manual of the respective sensor.

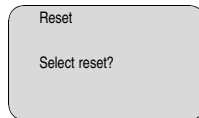

Service/Adjustment unit

In this menu item you select the internal arithmetic unit of the sensor.

With radar, guided microwave and ultrasonic sensors this is m(d) or ft(d).

For pressure transmitters more comprehensive units are available. They are described in the operating instructions manual of the respective sensor in the menu "*Basic adjustments*".

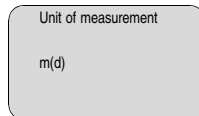

Service/Language

The sensor is already set to the ordered national language. In this menu item you can change the language. The following languages are available, e.g. in software version 3.50:

- Deutsch
- English
- Français
- Español
- Pycckuu
- Japanese
- Italiano
- Netherlands
- Japanese
- Chinese

²⁾ Special parameters are parameters which are set customer-specifically on the service level with the adjustment software PACTware.

³⁾ Temperature only with pressure transmitters and ultrasonic sensors.

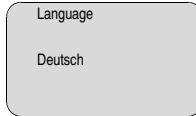

Service/Copy sensor data

With this function

- Load parameter adjustment data from the sensor into the indicating and adjustment module
- Write parameter adjustment data from the indicating and adjustment module into the sensor

The data are permanently saved in an EEPROM memory in the indicating and adjustment module and remain there even in case of power failure. From there, they can be written in one or several sensors or kept as backup for a probable sensor exchange.

Kind and volume of the copied data depend on the respective sensor.



Information:

Before writing the data into the sensor, it is checked if the data fit the sensor. If data do not fit, a fault signal is triggered or the function is blocked. When writing data into the sensor, you will see from which instrument type the data originate and which TAG-no. this sensor had.

The following items are checked:

- Software version
- WHG approval
- SIL activated
- Measuring principle
- Radar C-band/K-band
- Radar measuring range < 30 m or > 30 m
- Signal output
- Pressure measuring range

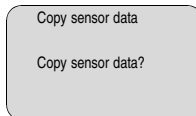

Service/PIN

In this menu item, the PIN is activated/deactivated permanently. Entering a 4-digit PIN protects the sensor data against unauthorized access and unintentional modifications. If the PIN is activated permanently, it can be deactivated temporarily (i.e. for approx. 60 min.) in any menu item. The instrument is delivered with the PIN set to 0000.

Disable permanently?

Only the following functions are permitted with activated PIN:

- Select menu items and show data
- Read data from the sensor into the indicating/adjustment module.

Info/Info

In this menu item the most important sensor information can be displayed:

- Instrument type
- Serial number: 8-digit number, e.g. 12345678

Instrument type

Serial number
12345678

- Date of manufacture: Date of the factory calibration, e.g. 10. January 2008
- Software version: Edition of the sensor software, e.g. 3.50

Date of manufacture
10. January 2008
Software version
3.50

- Date of last change using PC: Date of the last change of sensor parameters via PC, e.g. 10. January 2008

Last change using PC

10. January 2008

- Sensor details, e.g. approval, process fitting, seal, measuring cell, measuring range, electronics, housing, cable entry, plug, cable length etc.

Sensor characteristics

Display now?

5.2 Adjustment menu 4 ... 20 mA/HART

Display/Display

In the menu item "*Display*" you can define how the measured value should be presented on the display.

The following values can be displayed:

- Height
- Pressure (only with pressure transmitters)
- Distance (only with radar, guided microwave, ultrasonics)
- Current
- Scaled
- Percent
- Lin. percent
- Temperature (only with pressure transmitters).

The selection "scaled" opens the menu items "Display unit" and "Scaling". In "Display unit" there are the following options:

- Height
- Mass
- Flow
- Volume
- Without unit

Depending on selection, the different units are in turn available.

In the menu item "Scaling", the requested numerical value with decimal point is entered for 0 % and 100 % of the measured value.

There is the following relation between the indication value in the menu "Display" and the adjustment unit in the menu "Basic adjustment":

- With radar, guided microwave and ultrasonics, displayed value "Distance" means: presentation of the measured value in the selected adjustment unit, e.g. m(d)
- With pressure, displayed value "Pressure" or "Height" means: presentation of the measured value in the selected adjustment unit, e.g. bar or m.

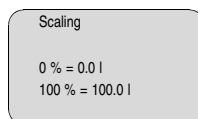
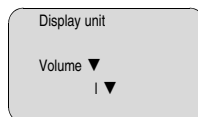
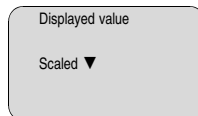

Service/Current output

In the menu item "Current output" you determine the behaviour of the current output during operation and in case of failure. The following options are available:

Current output

Characteristics curve	4 ... 20 mA 20 ... 4 mA
Failure mode ⁴⁾	Hold value 20.5 mA 22 mA < 3.6 mA
Min. current ⁵⁾	3.8 mA 4 mA
Max. current ⁶⁾	20 mA 20.5 mA

The values in bold font represent the data of the factory setting.

In HART multidrop mode, the current is constantly 4 mA. This value does not change even in case of failure.

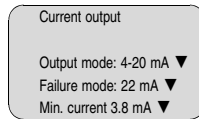
**Service/Functional safety (SIL)**

The functional safety is already activated Ex factory for instruments with SIL qualification. For instruments Ex factory without SIL qualification, the functional safety must be activated by the user for applications according to SIL via the indicating and adjustment module. The SIL factory setting cannot be deactivated by the user.

The activation of SIL has the following impact:

- In the menu item "*Failure mode*" under "*Current output*", the parameters "*Hold value*" and "*20.5 mA*" are blocked
- In the menu item "*HART mode*", the function "*Multidrop*" is blocked

**Note:**

For such applications, it is absolutely necessary to take note of "*Safety Manual*".

Service/HART mode

HART offers standard and multidrop mode.

The mode standard with the fixed address 0 means output of the measured value as 4 ... 20 mA signal.

⁴⁾ Value of the current output in case of failure, e.g. if no valid measured value is delivered.

⁵⁾ This value is not underrun during operation.

⁶⁾ This value is not exceeded during operation.

In Multidrop mode, up to 15 sensors can be operated on one two-wire cable. An address between 1 and 15 must be assigned to each sensor.⁷⁾

In this menu item you determine the HART mode and enter the address for multidrop.

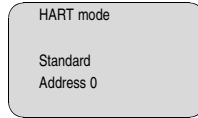

The default setting is standard with address 0.

5.3 Adjustment menu Profibus PA

Basic adjustment/Sensor address

Level and pressure sensors operate as slaves on the Profibus PA. To be identified as a bus participant, each sensor must have a unique address. Each instrument is delivered with address 126. With this address, it can at first be connected to an existing bus. However, the address must be changed. This can be done in this menu item.

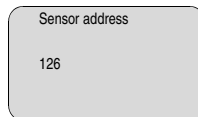

Channel

The channel is the input selector switch for function block (FB) of the sensor. Within the function block, additional scalings (Out-Scale) are carried out. In this menu item, the value for the function block is selected:

- SV1 (Secondary Value 1):
 - Percent with radar, guided microwave and ultrasonic sensors
 - Pressure or height with pressure transmitters
- SV2 (Secondary Value 2):
 - Distance with radar, guided microwave and ultrasonic sensors
 - Percent with pressure transmitters
- PV (Primary Value):
 - Linearised percentage value

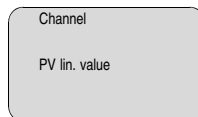

⁷⁾ The 4 ... 20 mA signal of the HART sensor is switched off. The sensor consumes a constant current of 4 mA. The measuring signal is transmitted exclusively as digital HART signal.

Display/Display

Radar, guided microwave and ultrasonic sensors deliver the following measured values:

- SV1 (Secondary Value 1): Percentage value after the adjustment
- SV2 (Secondary Value 2): Distance value before the adjustment
- PV (Primary Value): Linearised percentage value
- PA-Out (value after passing the function block): PA output

A pressure transmitter delivers the following measured values:

- SV1 (Secondary Value 1): Pressure or height value before adjustment
- SV2 (Secondary Value 2): Percentage value after the adjustment
- PV (Primary Value): Linearised percentage value
- PA-Out (value after passing the function block): PA output
- Temperature

In the menu item "*Display*" you can define which measured value should be presented on the display.

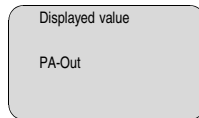
**Service/Additional PA value**

Profibus transmits two values cyclically. The first value is determined in the menu item "*Channel*". The selection of the additional cyclical value is made in the menu item "*Additional PA value*".

The following values are available with radar, guided microwave and ultrasonic sensors:

- SV1 (Secondary Value 1): Percentage value after the adjustment
- SV2 (Secondary Value 2): Distance value before the adjustment
- PV (Primary Value): Linearised percentage value

With pressure transmitters the following values are available:

- SV1 (Secondary Value 1): Pressure or height value before adjustment
- SV2 (Secondary Value 2): Percentage value after the adjustment
- PV (Primary Value): Linearised percentage value

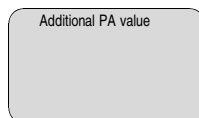

Service/Determine Out-Scale

Here, you determine the unit and scaling for PA-Out. These settings also apply to the values displayed on the indicating and adjustment module if in the menu item "*Displayed value*" PA-Out was selected.

The following displayed values are available in "Out-Scale unit":

- Pressure (only with pressure transmitters)
- Height
- Mass
- Flow
- Volume
- Others (no unit, %, mA)

In the menu item "*PV-Out-Scale*", the requested numerical value with decimal point is entered for 0 % and 100 % of the measured value.

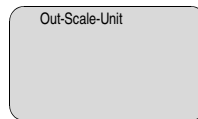

6 Set up - Sensors from HW 2.0.0 and SW 4.0.0

6.1 Adjustment menu for all signal outputs

With the parameter adjustment, the instrument is adapted to the application conditions. The parameter adjustment is carried out via an adjustment menu.



Information:

In this operating instructions, all general parameters are described. Further, instrument-specific parameters are described in the operating instructions of the respective sensor.

Measured value indication

The following presentations are available in the measured value display:

- Level as digital value, sensor TAG
- Level as digital value and bar graph, sensor TAG

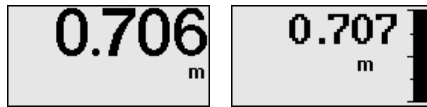

With [**->**] you select the different presentations of the measured value. You can reach the menu overview from any presentation with [**OK**]. With [**ESC**] you return from the menu overview to the measured value display.

Main menu

The main menu is divided into five areas with the following functions:

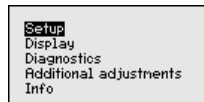

Setup: Contains settings for medium, application, vessel, adjustment, signal output as well as device TAGs

Display: Contains language changeover, settings to the indicated measured value as well as for lighting

Diagnostics: Contains information on pointer, reliability, echo curve and simulation

Additional settings: Contains false signal suppression, linearization curve, sensor length, reset, adjustment unit, SIL function, HART mode

Info: Shows instrument type, serial number, software version, last change, sensor characteristics

Setup/Measurement loop name

In the menu item "Sensor-TAG" you edit a 12-digit measurement loop name. An unambiguous designation can hence be assigned to the sensor, e.g. the measurement loop name or the tank or product designation. In digital systems and in the documentation of larger plants, a singular designation should be entered for exact identification of individual measuring sites.

The available digits comprise:

- Letters from A ... Z
- Numbers from 0 ... 9
- Special characters +, -, /, -

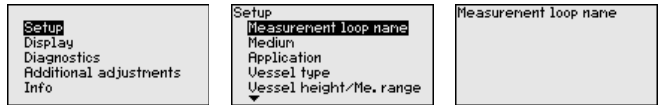

Setup/Damping

To damp process-dependent measured value fluctuations, you have to set an integration time of 0 ... 999 s in this menu item.

Depending on the sensor type, the factory setting is 0 s or 1 s.

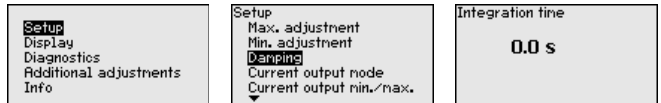

Display/Language

In the delivery status, the sensor is set to the ordered national language.

This menu item enables the setting of another national language.

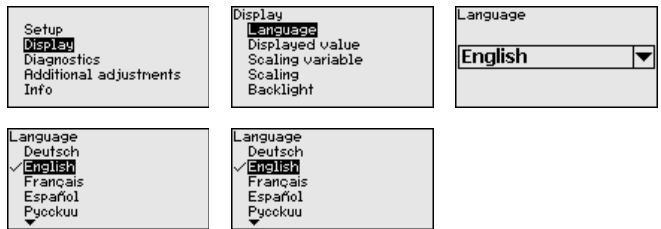

Display/Lighting

The optionally integrated background lighting can be adjusted via the adjustment menu. The function depends on the height of the supply voltage, see operating instructions of the respective sensor.

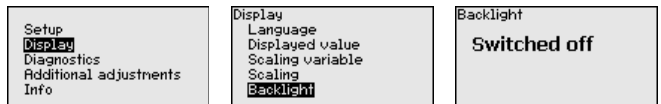

The lighting is switched off in the delivery status.

Diagnosis/Device status In this menu item, the device status is displayed.

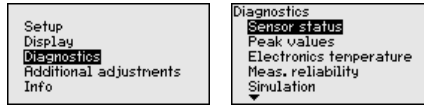

Diagnosis/Pointer Min. and max. measured values are saved in the sensor. The values are displayed in the menu item "Peak values".

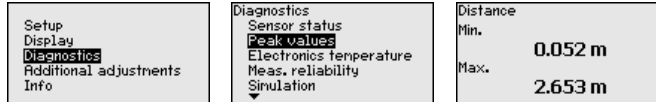

Diagnosis/Electronics temperature In this menu item, the electronics temperature is displayed.

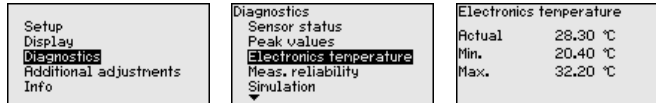

Diagnosis/Simulation In this menu item you simulate measured values via the current output. This allows the signal path to be tested, e.g. via connected indicating instruments or the input card of the processing system.

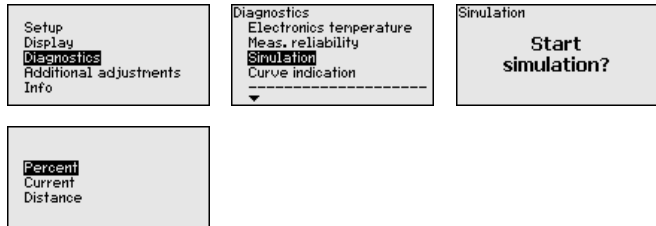

Information:

With Profibus PA sensors, the selection of the simulated value is made via the "Channel" in the menu "Basic adjustments".

How to start the simulation:

- 1 Push **[OK]**
- 2 Select the requested simulation variable with **[->]** and confirm with **[OK]**
- 3 Set the requested numerical value with **[+]** and **[->]**.
- 4 Push **[OK]**

The simulation is now running, with 4 ... 20 mA/HART a current is outputted and with Profibus PA or Foundation Fieldbus a digital value.

How to interrupt the simulation:

→ Push **[ESC]**



Information:

The simulation is terminated automatically 10 minutes after the last key has been pushed.

Additional settings/Device settings

In this menu item, you select the measured variable of the system.

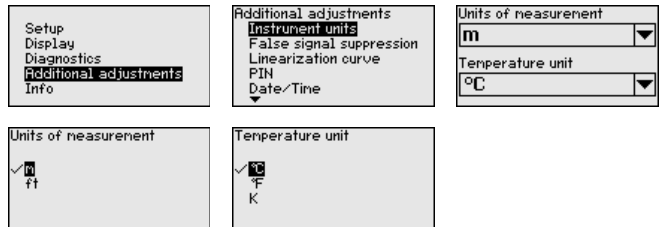

Further settings/Linearization

A linearization is necessary for all vessels in which the vessel volume does not increase linearly with the level - e. g. in a horizontal cylindrical or spherical tank - and the indication or output of the volume is required. Corresponding linearization curves are preprogrammed for these vessels. They represent the correlation between the level percentage and vessel volume. The linearisation applies to the measured value indication and the current output. By activating the appropriate curve, the volume percentage of the vessel is displayed correctly. If the volume should not be displayed in percent but e.g. in l or kg, a scaling can be also set in the menu item "Display".

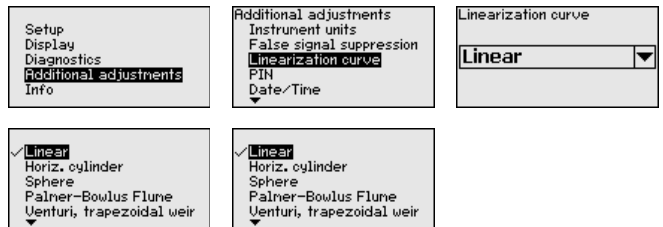

Caution:

Note the following, if the respective sensor is used as part of an overflow protection system according to WHG:

If a linearisation curve is selected, the measuring signal is no longer compulsorily linear proportional to the level. This must be taken into consideration by the user, particularly when adjusting the switching point on the level switch.

Additional settings/PIN

In this menu item, the PIN is activated/deactivated permanently. Entering a 4-digit PIN protects the sensor data against unauthorized access and unintentional modifications. If the PIN is activated permanently, it can be deactivated temporarily (i.e. for approx. 60 min.) in any menu item. The instrument is delivered with the PIN set to 0000.

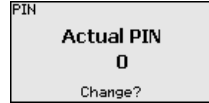
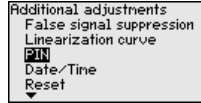
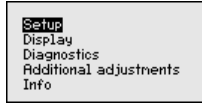
**Caution:**

With active PIN, the adjustment via PACTware/DTM as well as other systems is also blocked.

Only the following functions are permitted with activated PIN:

- Select menu items and show data
- Read data from the sensor into the indicating/adjustment module.

In delivery status, the PIN is "0000".

Further settings/Date and time

The instrument has an internal clock.

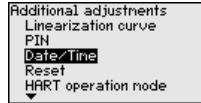
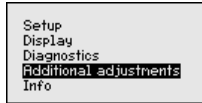
**Further settings/Copy sensor settings**

With this function the sensor settings are copied. The following functions are available:

- Store data from the sensor into the indicating/adjustment module.
- Store data from the indicating and adjustment module in the sensor

The following data or settings for adjustment of the indicating and adjustment module are saved:

- All data of the menu "Setup" and "Display"
- In the menu "Additional settings" the items "Distance unit, temperature unit and linearization"
- The values of the user programmable linearization curve

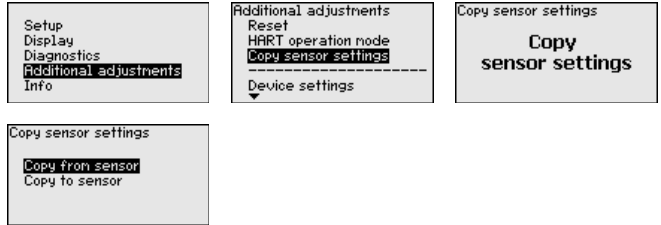

The copied data are permanently saved in an EEPROM memory in the indicating and adjustment module and remain there even in case of power failure. From there, they can be written into one or more sensors or kept as backup for a possible sensor exchange.

Kind and volume of the copied data depend on the respective sensor.



Note:

Before the data are stored in the sensor, a check is carried out to determine if the data fit the sensor. If the data do not fit, a fault signal is triggered or the function is blocked. When data are being written into the sensor, the display shows which instrument type the data originate from and which TAG-no. this sensor had.

Info/Instrument type

In this menu, you read out the instrument name and the instrument serial number:

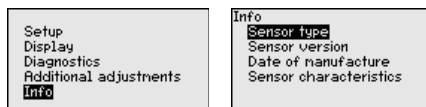

Info/Sensor version

In this menu item, the hardware and software version of the sensor is displayed.

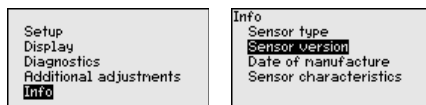

Info/Calibration date

In this menu item, the date of factory calibration of the sensor as well as the date of the last change of sensor parameters are displayed via the indicating and adjustment module or via the PC.

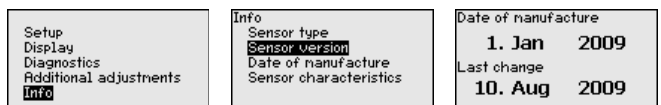

Sensor characteristics

In this menu item, the features of the sensor such as approval, process fitting, seal, measuring range, electronics, housing and others are displayed.

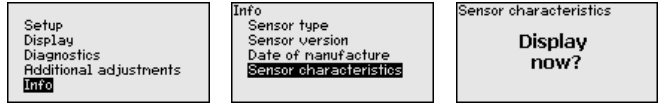

6.2 Adjustment menu 4 ... 20 mA/HART

Setup/Current output mode

In the menu item "Current output mode" you determine the output characteristics and the fault mode of the current output.

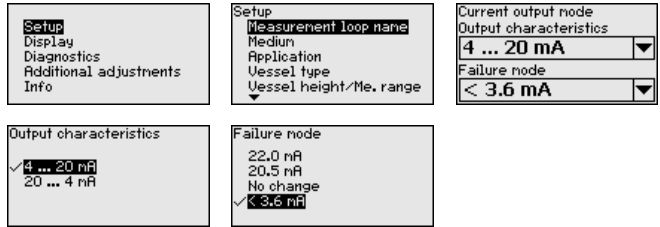

Setup/Current output Min./Max.

In the menu item "Current output Min./Max.", you determine the reaction of the current output during operation and in case of failure.

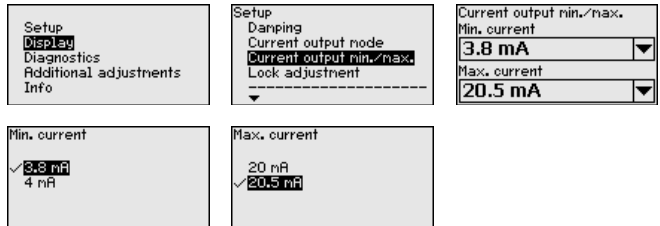

Display/Displayed value

In this menu item, you define how the measured value is displayed.

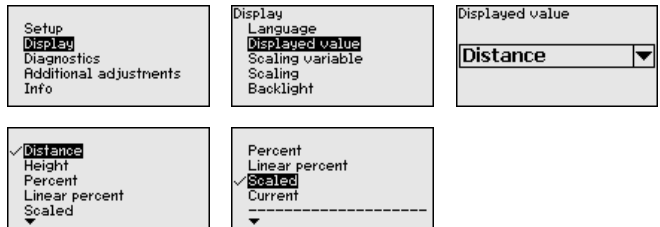

There is the following relationship between the indication value in the menu "Display" and the adjustment unit in the menu "Device settings":

- With radar, guided microwave and ultrasonic sensors, displayed value "Distance" means: presentation of the measured value in the selected adjustment unit, e.g. m(d)
- With pressure transmitters, displayed value "Pressure" or "Height" means: presentation of the measured value in the selected adjustment unit, e.g. bar or m.

Display/Scaling size

In this menu item, you define the scaling of the measured value on the display.

In the menu item "Scaling", the requested numerical value with decimal point is entered for 0 % and 100 % of the measured value.

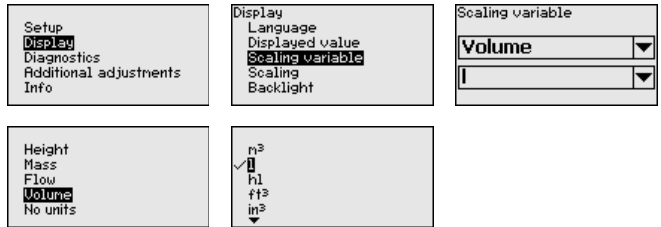

Display/Scaling

In this menu item, you define the scaling of the measured value on the display.

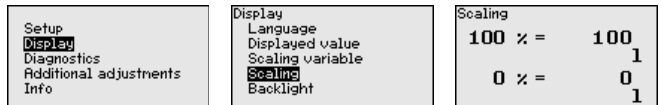

Further settings/HART mode

The sensor offers the HART modes standard and Multidrop. In this menu item you determine the HART modes and enter the address with Multidrop.

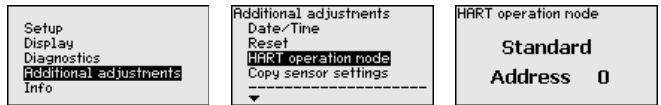

The mode standard with the fixed address 0 means output of the measured value as 4 ... 20 mA signal.

In Multidrop mode, up to 63 sensors can be operated on one two-wire cable. An address between 1 and 126 must be assigned to each sensor.⁸⁾

The default setting is standard with address 0.

⁸⁾ The 4 ... 20 mA signal of the HART sensor is switched off. The sensor consumes a constant current of 4 mA. The measuring signal is transmitted exclusively as digital HART signal.

7 Maintenance and fault rectification

7.1 Maintenance

When the device is used correctly, no maintenance is required in normal operation.

7.2 How to proceed in case of repair

If a repair is necessary, please proceed as follows:

You can download a return form (23 KB) from our Internet homepage www.vega.com under: "*Downloads - Forms and certificates - Repair form*".

By doing this you help us carry out the repair quickly and without having to call back for needed information.

- Print and fill out one form per instrument
- Clean the instrument and pack it damage-proof
- Attach the completed form and, if need be, also a safety data sheet outside on the packaging
- Please ask the agency serving you for the address of your return shipment. You can find the respective agency on our website www.vega.com.

8 Dismount

8.1 Dismounting steps

**Warning:**

Before dismantling, be aware of dangerous process conditions such as e.g. pressure in the vessel, high temperatures, corrosive or toxic products etc.

Take note of chapters "*Mounting*" and "*Connecting to power supply*" and carry out the listed steps in reverse order.

8.2 Disposal

The instrument consists of materials which can be recycled by specialised recycling companies. We use recyclable materials and have designed the electronics to be easily separable.

WEEE directive 2002/96/EG

This instrument is not subject to the WEEE directive 2002/96/EG and the respective national laws. Pass the instrument directly on to a specialised recycling company and do not use the municipal collecting points. These may be used only for privately used products according to the WEEE directive.

Correct disposal avoids negative effects to persons and environment and ensures recycling of useful raw materials.

Materials: see chapter "*Technical data*"

If you have no possibility to dispose of the old instrument professionally, please contact us concerning return and disposal.

9 Supplement

9.1 Technical data

General data

Weight	approx. 150 g (0.33 lbs)
--------	--------------------------

Ambient conditions

Ambient temperature	-15 ... +70 °C (+5 ... +158 °F)
Storage and transport temperature	-40 ... +80 °C (-40 ... +176 °F)

Indicating and adjustment module

Voltage supply and data transmission	through the sensor
Indication	LC display in dot matrix
Adjustment elements	4 keys
Protection rating	
– unassembled	IP 20
– mounted into the sensor without cover	IP 40
Materials	
– Housing	ABS
– Inspection window	Polyester foil

Display light

Power supply	through the sensor, voltage range see sensor operating instructions manual
--------------	--

9.2 Dimensions

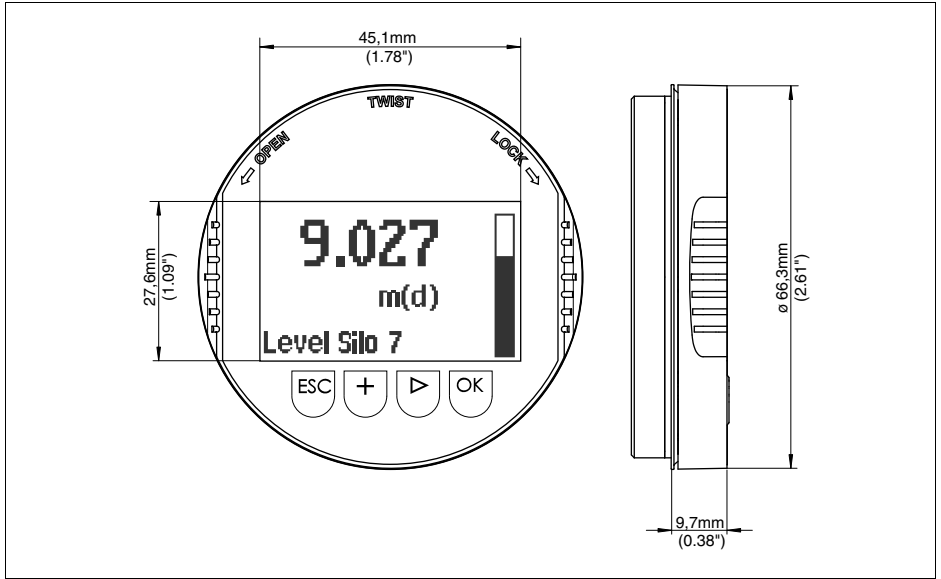

Fig. 3: Dimensions PLICSCOM

9.3 Industrial property rights

VEGA product lines are global protected by industrial property rights. Further information see <http://www.vega.com>.

Only in U.S.A.: Further information see patent label at the sensor housing.

VEGA Produktfamilien sind weltweit geschützt durch gewerbliche Schutzrechte.

Nähere Informationen unter <http://www.vega.com>.

Les lignes de produits VEGA sont globalement protégées par des droits de propriété intellectuelle. Pour plus d'informations, on pourra se référer au site <http://www.vega.com>.

VEGA lineas de productos están protegidas por los derechos en el campo de la propiedad industrial. Para mayor información revise la pagina web <http://www.vega.com>.

Линии продукции фирмы ВЕГА защищаются по всему миру правами на интеллектуальную собственность. Дальнейшую информацию смотрите на сайте <http://www.vega.com>.

VEGA系列产品在全球享有知识产权保护。
进一步信息请参见网站<<http://www.vega.com>>。

9.4 Trademark

All the brands as well as trade and company names used are property of their lawful proprietor/originator.

INDEX

A

- Additional PA value
 - Primary Value 22
 - Secondary Value 22
- Adjustment system 10
- Application area 7

C

- Channel with Profibus PA 21
- Copy sensor data 17
- Copy sensor settings 28
- Current output 19
- Current output Min./Max. 30

D

- Damping 11, 25
- Date of manufacture 29
- Date/Time 28
- Display 18
- Display with Profibus PA 22
- Displayed value 30

E

- Echo curve 14
- Electronics temperature 26

F

- Functional range 7
- Functional safety (SIL) 20

H

- HART mode
 - Multidrop 20, 31
 - Standard 20, 31

I

- Info 18
- Instrument type 29
- Instrument versions 7

K

- Key function 10

L

- Language 16, 25
- Lighting 13, 25
- Linearisation 27
- Linearisation curve 11

M

- Main menu 11, 24
- Meas. reliability 13
- Measured value indication 11, 24
- Measured value presentation 18
- Measured variable of the system 27
- Measurement loop name 25

O

- Out-Scale with Profibus PA 23

P

- PIN 17, 28
- Pointer 13, 26
- Power supply 7

R

- Reset 15

S

- Scaling measured value for display 31
- Scaling of the measured value for display 31
- Sensor address Profibus PA 21
- Sensor characteristics 30
- Sensor status 13, 26
- Sensor version 29
- Sensor-TAG 12
- Simulation 15, 26

U

- Unit of measurement 16



Printing date:

VEGA Grieshaber KG
Am Hohenstein 113
77761 Schiltach
Germany
Phone +49 7836 50-0
Fax +49 7836 50-201
E-mail: info@de.vega.com
www.vega.com



All statements concerning scope of delivery, application, practical use and operating conditions of the sensors and processing systems correspond to the information available at the time of printing.

© VEGA Grieshaber KG, Schiltach/Germany 2009