

Console systems

Features



The performance capability of a machine or plant is decided at the console and operating unit.

Rittal have set new standards in ergonomics, visual appearance and functionality for the human/machine interface with the **TopConsole system**. In particular, the modularity of the interior installation and variability within the "human/machine interface" family has been significantly extended, and offers versatile flexibility thanks to its compatibility with TS 8 system accessories.



TopConsole system TP

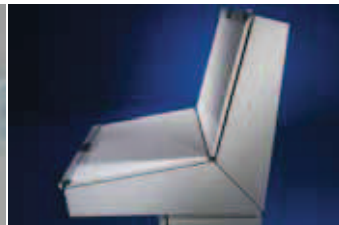
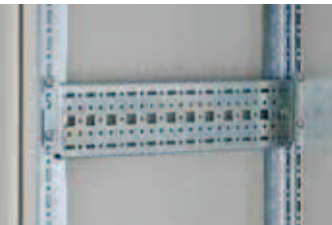

System configuration
The numerous components from the Rittal modular system produce a host of individual solutions which you are sure to find worthwhile.

Aesthetics
The slim, stylish design and the large surface are simply perfect.

Combination diversity
The TopConsole pedestal combined with a desk unit, CP-L support arm components and a Command Panel.



One-piece consoles AP



Cover
including perforated strips for cable routing. Safety lid stay may be unlatched with two-handed operation.

Door hinge
may be swapped from right to left by simply unscrewing the hinges.

Variable installation depth in the cover section
and cable entry from the rear via a mounting plate, height-adjustable by 2 x 40 mm.



Universal consoles AP

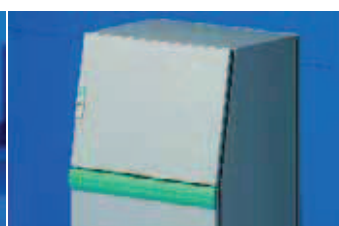

Optionally with short or tall door.
Short door for use with free panel for mounting desk section or keyboard drawer.

High stability and protection category
thanks to a body which is manufactured more or less from a single piece.

Universal interior installation
with partial mounting plates, component shelves, punched sections and rails.



Assembly

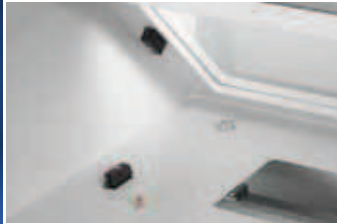

Easy assembly

The integrated "mounting assistant" can be used as an adjustment and securing aid: Simply insert, snap into position, and screw fasten.



Simple assembly

The fitted mounting plate slides in and locks easily into position (in a 25 mm pitch pattern). This depth variable installation and securing technology saves a lot of time and money during assembly and servicing.



Practical diversity

Perforated system strips fitted to doors and covers for TS compatible installation, i. e. for mounting rails or wiring plan pockets.

System configuration

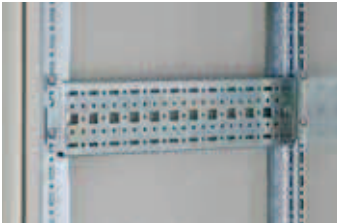

Individual interior configuration

The numerous components from the Rittal modular system produce a host of individual solutions which you are sure to find worthwhile.



Extra advantage

All TopConsole modules are fitted with threaded studs and are therefore ready for use in TS compatible configurations (rails, partial mounting plates and many more besides).



Exemplary cable routing

TopConsole system – also stands for more combination options for cable entries, thanks to individual gland plates.

Design, safety, ergonomics



Design line

The integrated lock, which is shielded by a hinged flap, is visually aligned with the handle strip.



Single-handed operation

The desk unit lid stay locks home automatically and it can be unlocked in one operation.

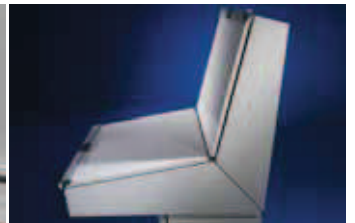

Stylish ergonomics

Screens, displays and operating controls are mounted at an ergonomically favourable angle.

Combination diversity



Example 1: The pedestal of a TopConsole combined with an IW worktop.



Example 2: The TopConsole pedestal combined with a desk unit, CP-L support arm components and a Command Panel.



Example 3: A TopConsole desk unit combined with an IW pedestal, 600 mm deep.

TopConsole System TP

Combination options

Easy selection of your desired combination

The TP TopConsole System components can be combined in many user specific versions as shown in the diagrams below. The table opposite allows you to immediately find the order number for your selection. In addition to this, the IW and Command Panel range make the new TopConsole system TP combination options virtually infinite.



Small operating units are easily integrated into separate Command Panels.



Completely new options with regard to space utilisation are available when used in conjunction with our range of IW enclosures.



The TS modular base/plinth system also ensures more cable entry flexibility even when used with consoles.

B
1.4

TopConsole System TP

Rittal human/machine interface family

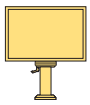

Command Panels may be found on page 190.

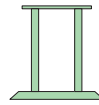
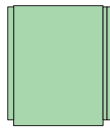

Industrial Workstations (IW) may be found from page 172.

Combination with console base sections

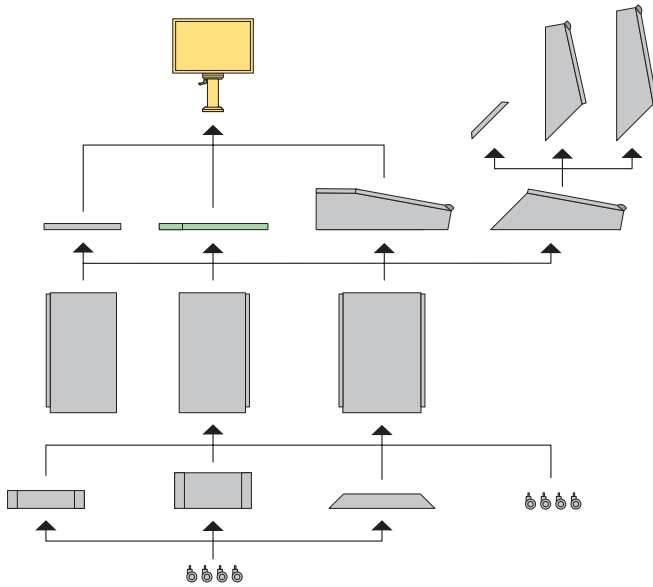

Combination with IW enclosures

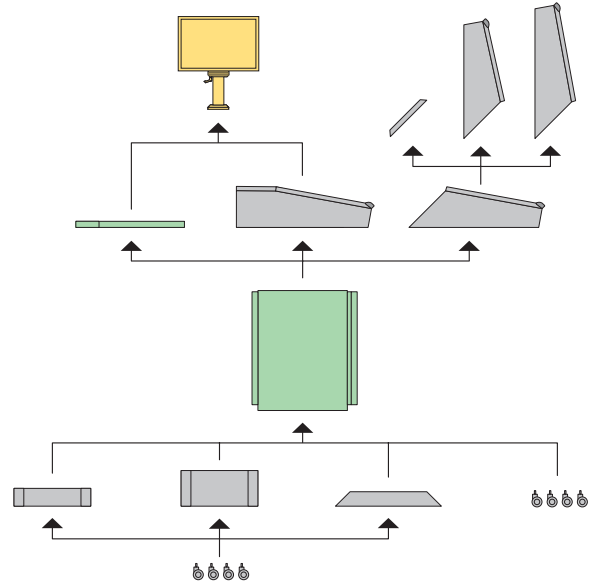

Combination with worktop base

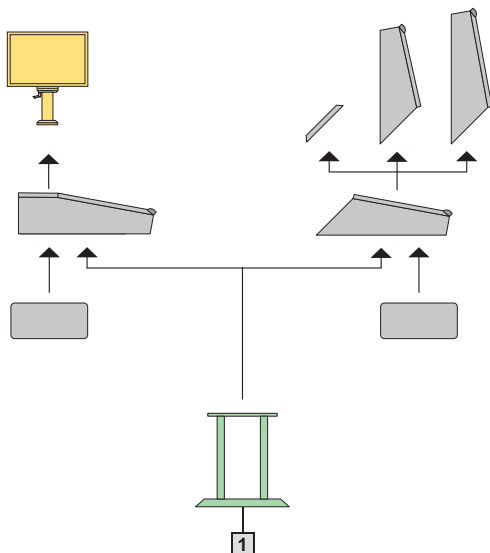



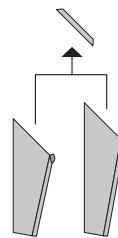







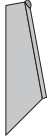

Upper section used as wall enclosure

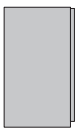

1 Worktop base for 800 mm width

TopConsole System TP

Overview table

Width mm		600		800		1200		1600	
		Model No.	Model No.	Model No.	Model No.	Model No.	Model No.	Model No.	Model No.
Console, upper section									
	Height 750 mm	6720.500		6721.500		6722.500		6723.500	
	Height 650 mm	6724.500		6725.500		6726.500		6727.500	
Desk unit already prepared for an upper section									
	Depth 755 mm	6714.500		6715.500		6716.500		6717.500	
Console/desk unit trim panel									
	for height 650/750 mm	6730.200		6730.210		6730.220		6730.230	
Rear of desk unit, with hinged lid									
	Depth 755 mm	6710.500		6711.500		6712.500		6713.500	
Gland plate for desk unit (from page 1048)									
	Size	4		5		4		5	
	Qty.	1		1		2		2	
Trim panel									
	D mm	400	500	400	500	400	500	400	500
		6730.000	6730.100	6730.010	6730.110	6730.020	6730.120	6730.030	6730.130
Pedestal									
	D mm	400	500	400	500	400	500	400	500
	Height 675 mm	6700.500	6704.500	6701.500	6705.500	6702.500	6706.500	6703.500	6707.500
Base/plinth components, front and rear									
	Height 200 mm	8602.600		8602.800		8602.200		8602.920	
	Height 100 mm	8601.600		8601.800		8601.200		8601.920	
Base/plinth trims, side									
	D mm	400	500	400	500	400	500	400	500
	Height 200 mm	8602.040	8602.050	8602.040	8602.050	8602.040	8602.050	8602.040	8602.050
	Height 100 mm	8601.040	8601.050	8601.040	8601.050	8601.040	8601.050	8601.040	8601.050
Cross member, adjustable									
	Height 75 mm	8601.450		8601.450		8601.450		8601.450	
Castors									
	Height 125 mm	4634.500		4634.500		4634.500		4634.500	

TopConsole System TP

Consoles

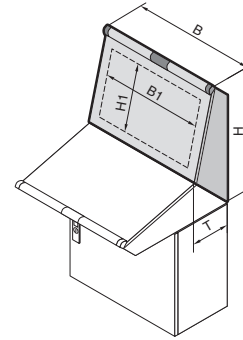

Material:

Sheet steel
Enclosure: 1.5 mm
Cover: 2.0 mm
Design handle strip: Aluminium
Corner protectors and lock lid:
Plastic, self-extinguishing

Surface finish:

Enclosure and cover:
Dipcoat-primed, powder-coated
in textured RAL 7035 on the
outside
Design handle strip:
Natural-anodised
Corner protectors and lock lid:
RAL 7015

Protection category:

IP 55 to EN 60 529/09.2000,
complies with NEMA 12
(when using a suitable trim
panel, see page 163,
or mounting on a desk unit).

Supply includes:

Enclosure with lid, hinged at the
bottom, may be swapped to the
top, includes lid stay,
open base for individual cable
entry.



Rittal service:

- Other sizes, cut-outs and holes available on request.
- Console for direct mounting on the pedestal using a trim panel.

Detailed drawing,
see page 1190.

Width (B) mm	Packs of	600	800	1200	1600	600	800	1200	1600	Page	
Height (H) mm		650	650	650	650	750	750	750	750		
Depth (T) mm		240	240	240	240	240	240	240	240		
Max. cut-out	Width (B1) mm	488	688	1088	1488	488	688	1088	1488		
	Height (H1) mm	313	313	313	313	413	413	413	413		
Model No. TP		6724.500	6725.500	6726.500	6727.500	6720.500	6721.500	6722.500	6723.500		
Accessories											
Trim panel (when used alone)		1	6730.200	6730.210	6730.220	6730.230	6730.200	6730.210	6730.220	6730.230	163
Rail for interior installation, horizontal	for width	4	5001.050	5001.051	5001.053	5001.055	5001.050	5001.051	5001.053	5001.055	992
Punched section with mounting flange 17 x 73 mm ¹⁾	for lid	4	8612.140	8612.140	8612.140	8612.140	8612.150	8612.150	8612.150	8612.150	993
	for enclosures	4	8612.150	8612.150	8612.150	8612.150	8612.150	8612.150	8612.150	8612.150	993
Support strip ¹⁾	for lid	20	4694.000	4694.000	4694.000	4694.000	4695.000	4695.000	4695.000	4695.000	997
	for enclosures	20	4695.000	4695.000	4695.000	4695.000	4695.000	4695.000	4695.000	4695.000	997
Punched rail 18 x 38 mm ¹⁾	for lid	4	8612.240	8612.240	8612.240	8612.240	8612.250	8612.250	8612.250	8612.250	996
	for enclosures	4	8612.250	8612.250	8612.250	8612.250	8612.250	8612.250	8612.250	8612.250	996
Partial mounting plate	200 mm width	1	6730.310	6730.310	6730.310	6730.310	6730.310	6730.310	6730.310	6730.310	986
	500 mm width	1	6730.330	6730.330	6730.330	6730.330	6730.330	6730.330	6730.330	6730.330	986
	700 mm width	1	–	6730.340	6730.340	6730.340	–	6730.340	6730.340	6730.340	986
Lock systems											

Standard double-bit lock insert may be exchanged for 27 mm lock inserts, type A, see page 956.

To order primed consoles please add extension .800 to the Model No. Delivery times available on request.

¹⁾ Can be vertically mounted in lid and rear enclosure wall.



Interface flaps

as programming interface,
for maintenance access and
for connecting to network
structures.
Model No. see page 1151.

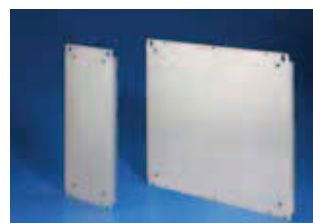

Partial mounting plate TP

200 mm, 500 mm and 700 mm
wide mounting plates are avail-
able as accessories. Screw-
fitting at the side enables sev-
eral partial mounting plates to
be bayed very quickly to form
a continuous mounting area.
Model No. see page 986.

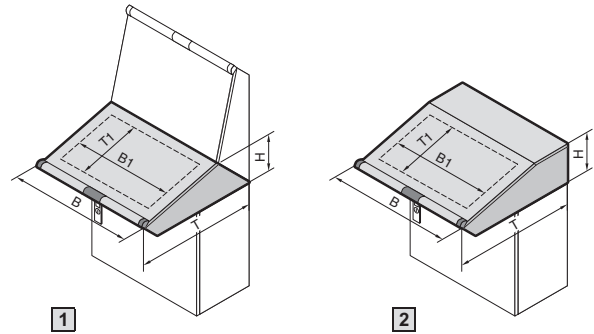

Material:

Sheet steel
Enclosure: 1.5 mm
Cover: 2.0 mm
Design handle strip: Aluminium
Corner protectors and lock lid: Plastic, self-extinguishing

Surface finish:

Enclosure and cover:
Dipcoat-primed, powder-coated in textured RAL 7035 on the outside
Design handle strip:
Natural-anodised
Corner protectors and lock lid:
RAL 7015

Protection category:

IP 55 to EN 60 529/09.2000, complies with NEMA 12 in combination with console, trim panel for console/desk unit and pedestal.

Supply includes:

Enclosure with lid, hinged at rear, 2 stays with automatic locking and unlocking, gland plate opening for cable entry in the enclosure base.



Rittal service:

- Other sizes, cut-outs and holes available on request.
- Console desk unit, with rear hinged lid, with mounting cut-out and CP-L support arm system reinforcement available upon request

1 Prepared for console: rear, open at top

2 Rear, with hinged lid

Detailed drawing, see page 1190.

		Packs of	1 Prepared for console				2 Rear, with hinged lid				Page
Width (B) mm			600	800	1200	1600	600	800	1200	1600	
Height (H) mm			235	235	235	235	235	235	235	235	
Depth (T) mm			750	750	750	750	750	750	750	750	
Max. cut-out console lid	Width (B1) mm		488	688	1088	1488	488	688	1088	1488	
	Depth (T1) mm		413	413	413	413	413	413	413	413	
Model No. TP			6714.500	6715.500	6716.500	6717.500	6710.500	6711.500	6712.500	6713.500	

Accessories

		Packs of	6730.200	6730.210	6730.220	6730.230	–	–	–	–	163
Trim panel for console/desk unit		1	6730.200	6730.210	6730.220	6730.230	–	–	–	–	163
Gland plate	Size		4	5	4	5	4	5	4	5	from 1048
	Qty.		1	1	2	2	1	1	2	2	1048
Rail for interior installation	for width	4	5001.050	5001.051	5001.053	5001.055	5001.050	5001.051	5001.053	5001.055	992
Punched section with mounting flange 17 x 73 mm ¹⁾	in depth	4	8612.150	8612.150	8612.150	8612.150	8612.150	8612.150	8612.150	8612.150	993
Support strip ¹⁾	in depth	20	4695.000	4695.000	4695.000	4695.000	4695.000	4695.000	4695.000	4695.000	997
Punched rail 18 x 38 mm ¹⁾		4	8612.250	8612.250	8612.250	8612.250	8612.250	8612.250	8612.250	8612.250	996
	200 mm width	1	6730.310	6730.310	6730.310	6730.310	6730.310	6730.310	6730.310	6730.310	986
Partial mounting plate	500 mm width	1	6730.330	6730.330	6730.330	6730.330	6730.330	6730.330	6730.330	6730.330	986
	700 mm width	1	–	6730.340	6730.340	6730.340	–	6730.340	6730.340	6730.340	986

Lock systems

Standard double-bit lock insert may be exchanged for 27 mm lock inserts, type A, see page 956.

To order primed desk units please add extension .800 to the Model No. Delivery times available on request.

¹⁾ Can be mounted in the lid and enclosure base.



Metal gland plates

For closing the cable entry opening in the base when using without a pedestal, Model No. see page 1049.



Cable glands

of polyamide or brass, Model No. see page 1054.

TopConsole System TP

Pedestals

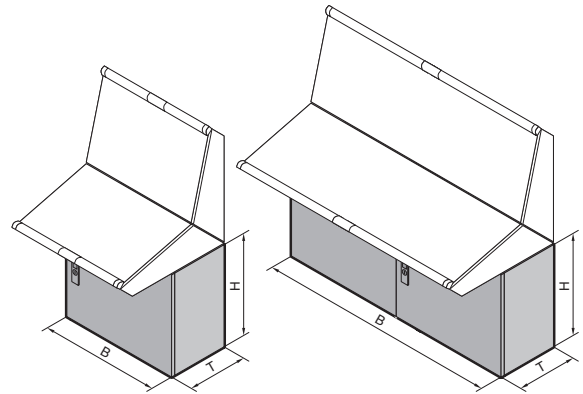

1.4 B TopConsole System TP

Material:

Sheet steel
Enclosure: 1.5 mm
Door: 2.0 mm
Mounting plate: 2.5 mm

Surface finish:

Enclosure and door:
Dipcoat-primed, powder-coated
in textured RAL 7035 on the
outside
Mounting plate: Zinc-plated

Protection category:

IP 55 to EN 60 529/09.2000,
complies with NEMA 12
(when using a suitable trim
panel, see page 163, or when
mounting on a desk unit and
selecting suitable gland plates,
see page 911).

Supply includes:

Enclosure, open at the top, door
or double door with locking rod
(with 400 mm depth at the front,
with 500 mm depth at the front
and rear), depth-adjustable
mounting plate, open base for
individual cable entry options.



Rittal service:

Other sizes, cut-outs and holes
available on request

Detailed drawing,
see page 1191.

Width (B) mm	Packs of	600	800	1200	1600	600	800	1200	1600	Page
Height (H) mm		675	675	675	675	675	675	675	675	
Depth (T) mm		400	400	400	400	500	500	500	500	
Model No. TP		6700.500	6701.500	6702.500	6703.500	6704.500	6705.500	6706.500	6707.500	
Door(s)		1	1	2	2	1/1	1/1	2/2	2/2	

Base/plinth

Components front and rear	Height 100 mm	1 set	8601.600	8601.800	8601.200	8601.920	8601.600	8601.800	8601.200	8601.920	893
	Height 200 mm	1 set	8602.600	8602.800	8602.200	8602.920	8602.600	8602.800	8602.200	8602.920	893
Trim panels (sides)	Height 100 mm	1 set	8601.040	8601.040	8601.040	8601.040	8601.050	8601.050	8601.050	8601.050	893
	Height 200 mm	1 set	8602.040	8602.040	8602.040	8602.040	8602.050	8602.050	8602.050	8602.050	893
Cross member, adjustable		2	8601.450	8601.450	8601.450	8601.450	8601.450	8601.450	8601.450	8601.450	903

Accessories

Trim panel for pedestal		1	6730.000	6730.010	6730.020	6730.030	6730.100	6730.110	6730.120	6730.130	163
Rail for interior installation	for height	4	5001.050	5001.050	5001.050	5001.050	5001.050	5001.050	5001.050	5001.050	992
Punched sections with mounting flanges, 17 x 73 mm	in depth	4	8612.140	8612.140	8612.140	8612.140	8612.150	8612.150	8612.150	8612.150	993
Punched rail 18 x 38 mm	in depth	4	8612.240	8612.240	8612.240	8612.240	8612.250	8612.250	8612.250	8612.250	996
Mounting bars	in depth	20	4694.000	4694.000	4694.000	4694.000	4695.000	4695.000	4695.000	4695.000	997
Punched sections with mounting flanges, 17 x 73 mm	for door	4	8612.050	–	8612.050	–	8612.050	–	8612.050	–	993
Mounting bars	for door	20	4596.000	4598.000	4596.000	4598.000	4596.000	4598.000	4596.000	4598.000	997
Cable clamp rail		1	5001.080	5001.081	5001.083	5001.084	5001.080	5001.081	5001.083	5001.084	1062
Wiring plan pocket		1	4116.500	4118.500	4116.500	4118.500	4116.500	4118.500	4116.500	4118.500	967

Lock systems

Standard double-bit lock insert, may be exchanged for 27 mm lock inserts, type A, see page 956 and for the Ergoform-S lock system, see page 953.

To order primed pedestals please add extension .800 to the Model No. Delivery times available on request.



Gland plates

- See page 911 for gland plates with different depths.
- Sections for cable entry, see page 1046.
- Cable entry plates, see page 1045.

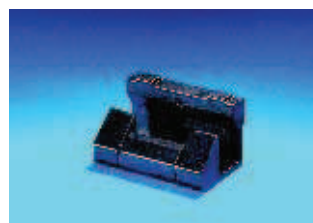

Hinges 180°

For retrospective conversion of standard doors with 130° hinges, including assembly parts.
Model No. see page 963.



Trim panel

for pedestal

For covering the complete top opening when using the pedestal on its own.

Material:
Sheet steel

Colour:
Textured RAL 7035

Protection category:
IP 55 to EN 60 529/09.2000,
complies with NEMA 12.

Supply includes:
Assembly parts.

For pedestal		Model No. TP
Width mm	Depth mm	
600	400	6730.000
800		6730.010
1200		6730.020
1600		6730.030
600	500	6730.100
800		6730.110
1200		6730.120
1600		6730.130



Trim panel

for console/desk unit

For covering the entire top opening when used alone.

Material:
Sheet steel

Colour:
Textured RAL 7035

Protection category:
IP 55 to EN 60 529/09.2000,
complies with NEMA 12.

Supply includes:
Assembly parts.

For console width mm	Model No. TP
600	6730.200
800	6730.210
1200	6730.220
1600	6730.230

Note:

Can be used with desk unit prepared for an upright console as well.

1

1 Console used as a wall-mounted enclosure



2

2 Trim panel on desk section

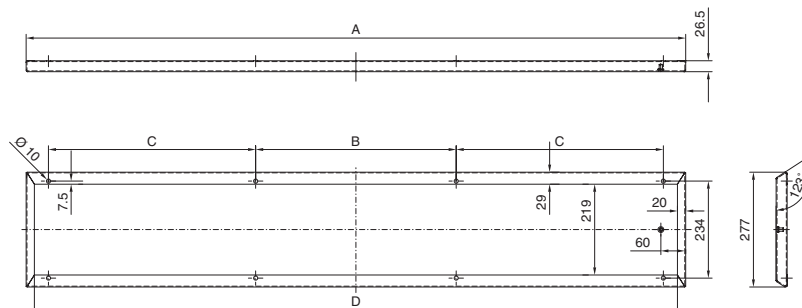

Model No. TP	Width mm	A	B	C	D
6730.200	600	592	484	–	552
6730.210	800	792	684	–	752
6730.220	1200	1192	384	350	1152
6730.230	1600	1592	484	500	1552

TopConsole System TP

Accessories



Attachment rail

For accessories such as scanner holder, shelf for printer etc. Mounting on the existing holes in the side groove between the pedestal and console. The enclosure protection category remains unaffected by this installation. No additional reinforcements are required for the pedestal. Holes can be drilled in the attachment rail prior to installation (e. g. for fitting screws, self-tapping screws or rivets).

To fit pedestal depth mm	Model No. TP
400	6730.500
500	6730.510

Material:

Rail: Sheet steel, zinc-plated, passivated
Cover caps: Plastic, black

Supply includes:

Assembly parts.



Baying rail

For baying the consoles at the installation site. Fitted in the side groove between the pedestal and the desk unit.

Material:

Rail: Sheet steel, zinc-plated, passivated
Cover caps: Plastic, black

Supply includes:

Assembly parts and baying seals.

To fit pedestal depth mm	Model No. TP
400	6730.520
500	6730.530

One-piece consoles AP

Sheet steel

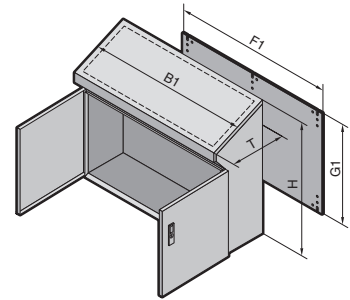
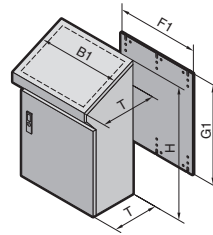

Material:

Sheet steel
Enclosure: 1.5 mm
Door and console lid: 2.0 mm
Mounting plate: 3.0 mm

Surface finish:

Enclosure, door and console lid:
Dipcoat-primed,
powder-coated in textured
RAL 7035 on the outside
Mounting plate and gland
plates: Zinc-plated

Colour:

Textured RAL 7035

Protection category:

IP 55 to EN 60 529/09.2000,
complies with NEMA 12.

Supply includes:

Enclosure, closed at the rear
and sides,
door or double door at the front,
console lid with stay,
gland plate, two-piece,
mounting plate.

Detailed drawing,
see page 1192.

Approvals,
see page 34.

B
1.4
One-piece consoles AP

Width (B1) mm	Packs of	600	800	1000	1200	Page
Height (H) mm		960	960	960	960	
Depth (T) mm		400/480	400/480	400/480	400/480	
Mounting plate width (F1) mm		530	730	930	1130	
Mounting plate height (G1) mm		780	780	780	780	
Model No. AP	1	2666.500	2668.500	2670.500	2672.500	
Door(s)		1	1	2	2	
Weight (kg)		52.0	65.2	79.5	90.3	

Accessories							
Base/plinth	Height 100 mm	1	2911.200	2901.200	2891.200	2921.200	901
	Height 200 mm	1	2912.200	2902.200	2892.200	2922.200	901
Cross member, adjustable		2	2697.450	2697.450	2697.450	2697.450	903
Aluminium strips		3	2676.000	2678.000	2682.000 ¹⁾	2682.000	1124
Swing frames		1	-	2027.200	2027.200	2027.200	1088

Lock systems

Console lid: Standard double-bit lock insert may be exchanged for 47 mm lock inserts, type D, see page 956.
Door: Standard double-bit lock insert, may be exchanged for 27 mm lock inserts, type A, see page 956, and for Ergoform-S lock system, see page 953.

¹⁾ To be shortened by 200 mm.

To order consoles in textured RAL 7032 please add extension .600 to the Model No., and for primed versions use extension .800.
Delivery times available on request.

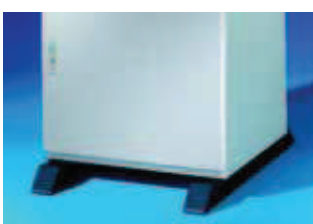

Adjustable cross member
Model No. see page 903.



Utility shelf, screw connection
for measuring instruments,
mouse or scanner.
Model No. see page 1123.

Universal consoles AP

Sheet steel

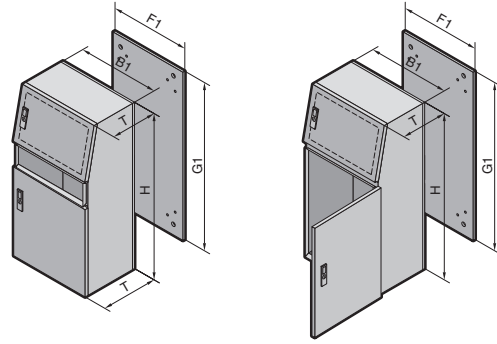

Material:

Sheet steel
Enclosure, gland plates: 1.5 mm
Doors: 2.0 mm
Mounting plate: 3.0 mm
Design strips (AP 2695.500):
Aluminium section

Surface finish:

Enclosure:
Dipcoat-primed, powder-coated in textured RAL 7035 on the outside
Mounting plate and gland plates: Zinc-plated

Colour:

Enclosure: Textured RAL 7035
Design strips (AP 2695.500):
RAL 5018

Protection category:

IP 55 to EN 60 529/09.2000, complies with NEMA 12. With a short bottom door (AP 2694.500), the drawer or desk section (see below) should be fitted in order to preserve the protection category.

Supply includes:

Enclosure with doors,
mounting plate,
gland plates,
design strips (AP 2695.500).

Note:

Top door with studs left and right for installing vertical perforated mounting strips SZ 2310.038 and horizontal support strips SZ 2325.000 to be mounted on top (see page 964/965). AP universal consoles are equivalent to free-standing

enclosure ES 5000 in terms of interior installation – in other words, the accessory components will fit.

Detailed drawing,
see page 1192.

Approvals,
see page 34.

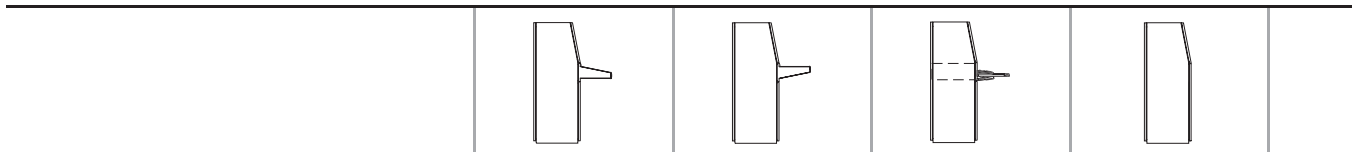

	Packs of	with short front door		with tall front door	Page
Width (B1) mm		600		600	
Height (H) mm		1300		1300	
Depth (T) mm		500/417.5		500/417.5	
Mounting plate width (F1) mm		499		499	
Mounting plate height (G1) mm		1196		1196	
Model No. AP	1	2694.500		2695.500	
Weight (kg)		77.0		80.0	

Also required					
Desk section		2696.500	2696.500	–	–
Drawer for keyboard		–	–	4757.500 ¹⁾	–

Accessories					
Base/plinth	Height 100 mm	1	2807.200	2807.200	901
	Height 200 mm	1	2808.200	2808.200	901
Cross member, adjustable		2	8601.450	8601.450	903
Cable clamp rail		1	4191.000	4191.000	1061

Lock systems
Standard double-bit lock insert, may be exchanged for 27 mm lock inserts, type A, see page 956 and for the Ergoform-S lock system, see page 953.

¹⁾ Only suitable for installation without a mounting plate.

To order in textured RAL 7032, please add extension .600 to the Model No. Delivery times available on request.



Keyboard drawer for universal console AP

For a max. keyboard width of 500 mm. With mousepad in the front section.

Packs of	Model No. AP
1	4757.500



Desk section for AP universal console

Solid sides and front, removable plates for top and bottom.

Packs of	Model No. AP
1	2696.500

PC enclosure systems

Features

Housing all your computer equipment, from the monitor, computer system, printer and keyboard to the mouse, becomes child's play with Rittal's PC enclosure systems. The result: perfect protection from humidity and dirt, temperature fluctuations and unauthorised access. What is more, these systems will exceed your expectations with regard to ergonomics, design and accessory diversity.

B
1.0

PC enclosure systems



IW enclosure for tower PC



Enclosure ready for connection to accommodate a standard tower PC in the door.



The fan-and-filter unit integrated as standard ensures optimum climate control at protection category IP 54.



The cast feet with twin castors ensure optimum stability and mobility.

PC enclosure systems based on TS 8, bayable

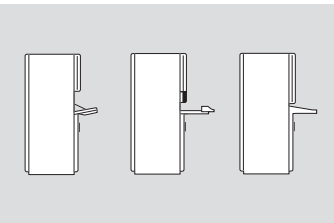

Operated via:

- Folding keyboard
- Keyboard drawer
- Desk section



Monitored with:

- Mounting compartment, large, or
- Glazed door, large, or
- Combination of small glazed door and small mounting compartment

PC enclosure systems based on ES

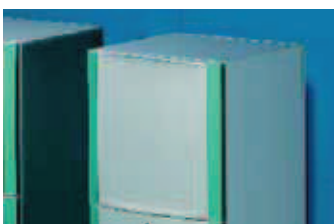

Operated via:

- Folding keyboard
- Keyboard drawer
- Desk section

Monitored with:

- Mounting compartment, large, or
- Glazed door, large, or
- Combination of small glazed door and small mounting compartment

PC enclosure systems

Based on TS 8, with keyboard drawer

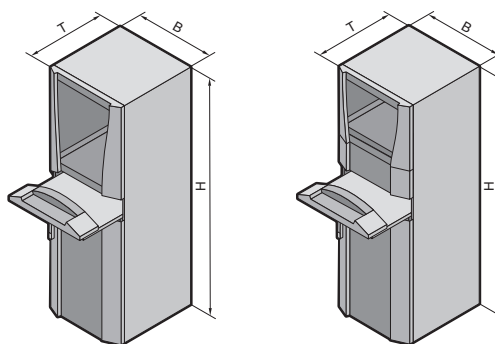

PC enclosure systems

1.4

Material:
see page 1193.

Supply includes,
see page 1193.

Approvals,
see page 35.

Protection category:
IP 55 to EN 60 529/09.2000,
complies with NEMA 12.

Detailed drawing,
see page 1193.

Design	Packs of	with keyboard drawer, glazed door, top	with keyboard drawer, glazed door, top	with keyboard drawer, glazed door, top, mounting compartment, small	with keyboard drawer, mounting compartment, large	Page
Width (B) mm		600	600	600	600	
Height (H) mm		1600	1600	1600	1600	
Depth (T) mm		636	836	636	636	
Model No. PC	1	8366.000	8368.000	8366.300	8366.400	
Max. keyboard dimensions mm	Width	480	480	480	480	
	Height	70	70	70	70	
	Depth	260	260	260	260	
Weight (kg)		118	133	118	117	

Accessories

Base/plinth, static		1	8800.920	on request	8800.920	8800.920	898
Base/plinth components front and rear	Height 100 mm	1	8601.600	8601.600	8601.600	8601.600	893
	Height 200 mm	1	8602.600	8602.600	8602.600	8602.600	893
Base/plinth trim, front	Height 200 mm	1	8360.920	8360.920	8360.920	8360.920	897
Base/plinth trim, side	Height 100 mm	1	8601.060	8601.080	8601.060	8601.060	893
	Height 200 mm	1	8602.060	8602.080	8602.060	8602.060	893
Cross member, adjustable	Height 70 mm	2	8601.680	8601.680	8601.680	8601.680	903
Partial mounting plate	Height 775 mm	1	8614.675	8614.675	8614.675	8614.675	984

Lock systems

Standard lock insert, may be exchanged for rear door: Lock inserts, type F, see page 956, comfort handle, see page 947.
Designer door, front: Lock inserts, type F, see page 956, comfort handle, see page 947 – 948 (via handle adaptor PC 8611.300, see page 934).
Keyboard drawer/fold-out tray: Lock inserts, 27 mm, version A, see page 956.



Handle set.
Model No. see page 1116.

PC enclosure systems

Based on TS 8, with folding keyboard or desk section

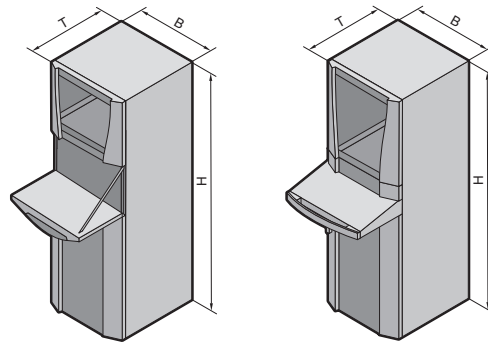

Material:
see page 1194.



Supply includes,
see page 1194.

Approvals,
see page 35.

Protection category:
IP 55 to EN 60 529/09.2000,
complies with NEMA 12.

Detailed drawing,
see page 1194.

B
1.4
PC enclosure systems

								
Design	Packs of	with folding keyboard, glazed door, top		with folding keyboard, glazed door, top		with desk section, glazed door, top		Page
Width (B) mm		600		600		600		
Height (H) mm		1600		1600		1600		
Depth (T) mm		636		836		636		
Model No. PC	1	8366.100		8368.100		8366.200		
Max. keyboard dimensions mm	Width	475		475		540		
	Height	60	50	60	50	40		
	Depth	200	250	200	250	175		
Weight (kg)		118		124		108		
Accessories								
Base/plinth, static	1	8800.920		on request		8800.920		898
Base/plinth components front and rear	Height 100 mm	8601.600		8601.600		8601.600		893
	Height 200 mm	8602.600		8602.600		8602.600		893
Base/plinth trim, front	Height 200 mm	8360.920		8360.920		8360.920		897
	Height 100 mm	8601.060		8601.080		8601.060		893
Base/plinth trim, side	Height 200 mm	8602.060		8602.080		8602.060		893
	Height 70 mm	8601.680		8601.680		8601.680		903
Partial mounting plate	Height 775 mm	8614.675		8614.675		8614.675		984

Standard lock insert, may be exchanged for rear door: Lock inserts, type F, see page 956, comfort handle, see page 947.
Designer door, front: Lock inserts, type F, see page 956, comfort handle, see page 947 – 948 (via handle adaptor PC 8611.300, see page 934).
Keyboard drawer/fold-out tray: Lock inserts, 27 mm, version A, see page 956.



Base/plinth trim panel PC
200 mm high.
Model No. see page 897.

PC enclosure systems

Based on ES, with keyboard drawer

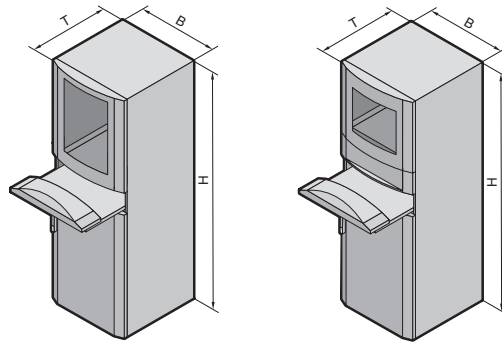

1.4 B PC enclosure systems

Material:
see page 1195.

Supply includes,
see page 1195.

Approvals,
see page 35.

Protection category:
IP 55 to EN 60 529/09.2000,
complies with NEMA 12.

Detailed drawing,
see page 1195.

Design	Packs of	with keyboard drawer, glazed door, top	with keyboard drawer, glazed door, top	with keyboard drawer, glazed door, top, mounting compartment, small	with keyboard drawer, mounting compartment, large	Page
Width (B) mm		600	600	600	600	
Height (H) mm		1600	1600	1600	1600	
Depth (T) mm		650	850	650	650	
Model No. PC	1	4603.703	4609.703	4603.913	4603.603	
Max. keyboard dimensions mm	Width	480	480	480	480	
	Height	55 ¹⁾ /40 ²⁾	55 ¹⁾ /40 ²⁾	55 ¹⁾ /40 ²⁾	55 ¹⁾ /40 ²⁾	
	Depth	250	250	250	250	
Weight (kg)		106	121	107	106	

Accessories							
Base/plinth, complete	Height 100 mm	1	2813.200	2846.200	2813.200	2813.200	901
	Height 200 mm	1	2814.200	2847.200	2814.200	2814.200	901
Cross member, adjustable		2	8601.680	8601.680	8601.680	8601.680	903
Twin castors		1 set	4634.500	4634.500	4634.500	4634.500	907
Mousepad, passive		1	4614.000	4614.000	4614.000	4614.000	1146

Lock systems
Standard lock insert, may be exchanged for rear door/designer door, front: Lock inserts, 27 mm, version A, see page 956.
Ergoform-S lock system, see page 953.
Keyboard drawer/fold-out tray: Lock inserts, 27 mm, version A, see page 956.

¹⁾ Without mousepad
²⁾ With mousepad

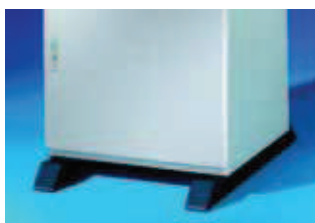

Cross member, adjustable.
Model No. see page 903.

PC enclosure systems

Based on ES, with folding keyboard or desk section

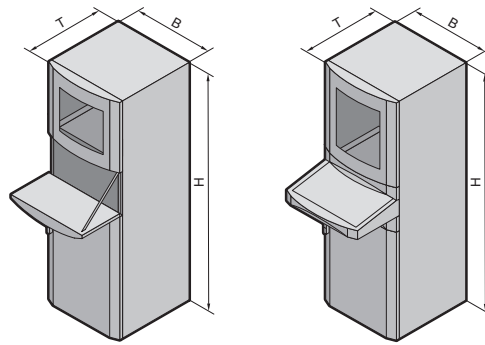

Material:
see page 1196.



Supply includes,
see page 1196.

Approvals,
see page 35.

Protection category:
IP 55 to EN 60 529/09.2000,
complies with NEMA 12.

Detailed drawing,
see page 1196.

B
1.4
PC enclosure systems

		 			
Design	Packs of	with folding keyboard, glazed door, top	with desk section, glazed door, top	Page	
Width (B) mm		600	600		
Height (H) mm		1600	1600		
Depth (T) mm		650	650		
Model No. PC	1	4603.920	4603.704		
Max. keyboard dimensions mm	Width	480	462		
	Height	69 ¹⁾ /62 ²⁾	40		
	Depth	230	208		
Weight (kg)		101	102		
Accessories					
Base/plinth, complete	Height 100 mm	1	2813.200	2813.200	901
	Height 200 mm	1	2814.200	2814.200	901
Cross member, adjustable		2	8601.680	8601.680	903
Twin castors		1 set	4634.500	4634.500	907
Mousepad, passive		1	4613.000	–	1146
Lock systems					
Standard lock insert, may be exchanged for rear door/designer door, front: Lock inserts, 27 mm, version A, see page 956.					
Ergoform-S lock system, see page 953.					
Keyboard drawer/fold-out tray: Lock inserts, 27 mm, version A, see page 956.					

¹⁾ Without mousepad
²⁾ With mousepad



Mobile workstation.
Model No. see page 1147.

Industrial Workstations

Features



For Rittal, Industrial Workstations means the ability to create professional workstations for virtually any application from a comprehensive modular system.

In combination with operating housings, support arm systems, PC enclosures and the diverse range of system accessories, there are virtually no limits to your creativity.

Here are few examples:

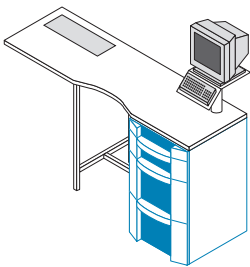

Workbench/assembly bench consisting of:

- IW enclosure
- IW pedestal
- Individual worktop

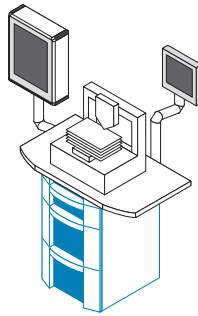

Laboratory equipment and small machinery consisting of:

- IW enclosure
- Worktop
- Support arm system
- Operating housings

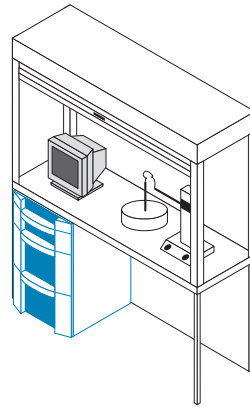

Protective cabinets:
With lockable roller blind on request.

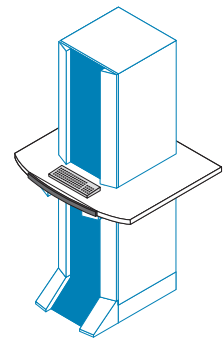

Measurement/control systems:
"More space" with the enclosure on top of the worktop.

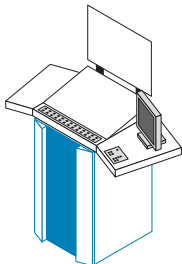

Control desks e. g. for printing presses consisting of:

- IW enclosure
- Individual worktop and assemblies

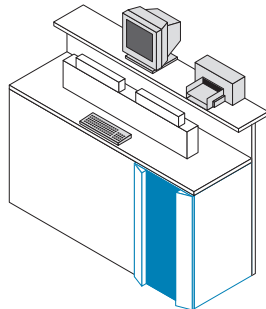

Workbench consisting of:

- IW enclosure for tools etc.
- Individual worktop with shelf for monitor, printer etc.

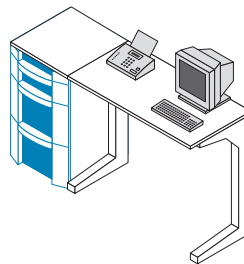

Calibration/measuring station consisting of:

- IW enclosure
- IW pedestal
- Worktop

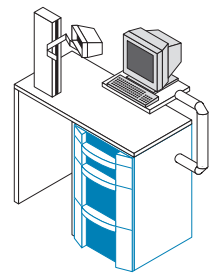

Programming station:
Ergonomically adaptable via the support arm system.

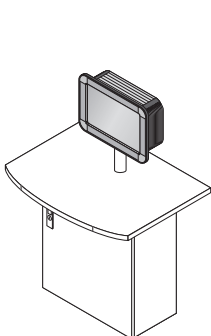

Production workstation consisting of:

- TP pedestal
- IW worktop
- Support arm system
- Operating housing

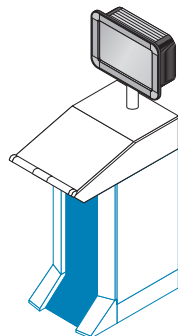

Workstation consisting of:

- Base/plinth
- IW enclosure
- TP desk unit
- Support arm system
- Operating housing

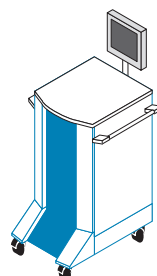

Mobile workstation/workshop trolley consisting of:

- Base/plinth with castors
- IW enclosure
- Worktop
- Handle system
- Operating housing

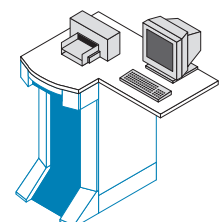

Scanner/PC station consisting of:

- IW enclosure
- Individual worktop

IW Quality Point/IW Logistic Point



The integration of a TFT monitor creates space on the work surface.

The rotatable printer shelf and the paper tray are a perfect duo for the secure accommodation of printers in an industrial environment.

Optimum glare-free illumination of the workplace with the integral workstation light.

IW enclosure



In two standard heights, optionally with designer door or glazed door. Offers plenty of storage space.

With drawer front for an orderly filing system. A pull-out lock which prevents the simultaneous opening of several drawers is integrated to increase operational safety.

If no enclosure is needed to accommodate documents or equipment, the IW pedestal may be used instead. By combining with a worktop, a large work surface is created.

IW monitor housing

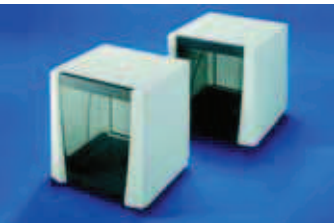

In two sizes for monitors up to 17" and 21" screen diagonal respectively. In conjunction with a turntable, the monitor can be viewed from all angles.

TFT monitors are increasingly being used in industrial environments. Thanks to the large number of standardised system components, TFTs may be easily integrated into the workstation.

Mounting of a TFT monitor without reducing the work space. With the aid of the enclosure attachment, the angle of the display is ideally adapted to suit the user.

IW worktops

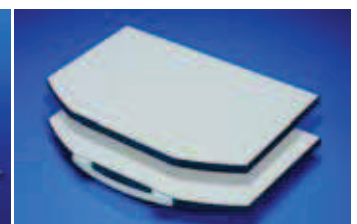

14 different worktops in 7 different sizes accommodate virtually all requirements.

Monitor housings may be mounted either rigidly or swivel-mounted on worktops prepared for a turntable.

Worktops with or without a handle – both variants are available off the shelf.

Industrial Workstations

Fast selection

Choose the appropriate IW components according to your requirements.

▶ Continue with system assembly using the item numbers shown beneath the arrow.

➡ System assembly can be completed here.

B
1.4

Industrial Workstations







1 Pre-configured complete solutions

<p>1.1 Quality Point L Width 1000 mm Height 2000 mm</p> <p>IW 6920.100</p> <p>Quality Point XL Width 2000 mm Height 2000 mm</p> <p>IW 6920.200 see page 177</p> <p>Logistic Point Width 1000 mm Height 2000 mm</p> <p>IW 6920.000 see page 178</p> 	<p>▶ 11.1</p>
<p>1.2 Enclosure with worktop Height 1000 mm</p> <p>IW 6901.100¹⁾ see page 181</p> 	<p>▶ 11.1 11.2 11.6</p> <p>➡</p>

¹⁾ The fitted version IW 6901.100 (with worktop) is also available with other worktops on request.



2 Monitor housing and add-ons

<p>2.1 Monitor housing 17" IW 6902.510</p> <p>Monitor housing 21" IW 6902.500 see page 185</p> 	<p>▶ 3.1 3.2</p>
<p>2.2 Optipanel For TFT monitors or other display and input units see page 206</p> <p>For 15" TFT CP 6380.010</p> <p>For 17" and 19" TFT CP 6380.030 see page 205</p> <p>TFT monitor 15"/17"/19" see page 1133</p> 	<p>▶ 3.3 3.4 3.5</p>
<p>2.3 Comfort Panel For TFT monitors or other display and input units see page 196</p> <p>For 15" TFT CP 6371.120/CP 6371.130/CP 6371.140</p> <p>For 17" TFT CP 6371.150/CP 6371.160/CP 6371.170 see page 194</p> <p>TFT monitor 15"/17"/19" see page 1133</p> 	<p>▶ 3.3 3.4 3.5</p>
<p>2.4 Quality Point attachment L Width 1000 mm Height 960 mm</p> <p>IW 6920.110</p> <p>Quality Point attachment XL Width 2000 mm Height 960 mm</p> <p>IW 6920.210 see page 185</p> 	<p>▶ 4.3 4.4 5 6 4.5 4.6</p>

Assembly example:

- 2.2** Optipanel
- 3.3** Support arm system CP-L
- 6.1** Worktop, prepared for enclosure attachment
- 9.1** Enclosure with drawer section
- 11.1** Base/plinth, stationary
- 11.6** Twin castors

3 Mounting comp. for monitor and operating housings

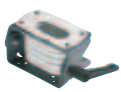

<p>3.1 Feet for monitor housing IW 6902.610 see page 186</p> 	
<p>3.2 Spacer plate for monitor housing IW 6902.630 rotatable in conjunction with: Turntable for spacer and support plate IW 6902.620 see page 187</p> 	 5
<p>3.3 Support arm system CP-L for rotatable, swivel and height-adjustable positioning of the Optipanel and Comfort Panel see page 250</p> 	 6
<p>3.4 Enclosure attachment tilting, top mounting¹⁾ IW 6902.670 see page 243</p> 	 6
<p>3.5 Enclosure attachment tilting, base mounting IW 6902.640 see page 257</p> 	 7

¹⁾ May also be used rotated through 180°.

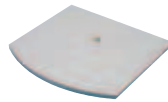

4 Worktops solid

<p>4.1 Cover solid Width 600 mm Depth 640 mm IW 6902.400 see page 182</p> 	
<p>4.2 Without handle Width 610 mm Depth 645 mm IW 6902.300 see page 183</p> 	
<p>4.3 Without handle Width 1000 mm Depth 895 mm IW 6902.100 see page 183</p> 	 8.1 8.2 8.3 8.4 9 10.1
<p>4.4 With handle Width 950 mm Depth 600 mm IW 6902.000 see page 183</p> 	 8.1 8.2 8.3 8.4 9.3 10.1
<p>4.5 Without handle Width 2000 mm Depth 685 mm IW 6902.200 see page 183</p> 	 8.1 8.2 8.3 8.4 10.1
<p>4.6 Without handle Width 2000 mm Depth 685/900 mm IW 6902.210 Width 2000 mm Depth 900/685 mm IW 6902.220 see page 183</p> 	 8.1 8.2 8.3 8.4 9 10.1

5 Worktops for turntable see 3.2/3.3



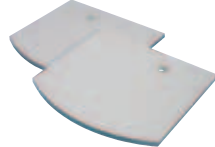

<p>5.1 Without handle solid Width 1000 mm Depth 895 mm IW 6902.110 see page 183</p> 	 8.1 8.2 8.3 8.4 9 10.1
--	--

6 Worktops prepared for enclosure attachment CP-L, Ø 130 mm see 3.4/3.5

<p>6.1 Without handle, prepared on left Width 1000 mm Depth 895 mm IW 6902.120¹⁾ Without handle, prepared on right Width 1000 mm Depth 895 mm IW 6902.130¹⁾ see page 184</p> 	 8.1 8.2 8.3 8.4 9 10.1
--	--

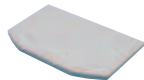
¹⁾ Hole may be used in conjunction with the adaptor plate for connector grommet IW 6902.660 (see page 1057) for cable entry!



7 Worktops for pedestal/enclosure for tower PC see 3.6

<p>7.1 Without handle Width 950 mm Depth 600 mm IW 6902.310 see page 184</p> 	 8.5 10.2
<p>7.2 With handle Width 950 mm Depth 658 mm IW 6902.320 see page 184</p> 	

Industrial Workstations

Fast selection

8 Cases with doors

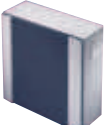
<p>8.1 Designer door, rear panel screw-fastened from the inside Height 900 mm IW 6900.000 see page 180</p> 	<p>▶ 11.1 11.2 11.6</p> <p>—</p>
<p>8.2 Designer door, rear panel screw-fastened from the outside Height 1000 mm IW 6901.000 see page 180</p> 	
<p>8.3 Designer door, solid, rear door Height 900 mm IW 6900.100 see page 180</p> 	
<p>8.4 Designer door, prepared as printer cabinet, rear door Height 900 mm IW 6900.110 see page 180</p> 	
<p>8.5 Glazed door, rear door Height 900 mm IW 6900.200 see page 180</p> 	
<p>8.6 Enclosure for tower PC Width 760 mm Height 760 mm IW 6900.300 see page 179</p> 	<p>▶ 10.3</p> <p>—</p>

9 Cases with drawers

<p>9.1 Drawer section, designer door, rear door Height 900 mm IW 6900.400 see page 181</p> 	<p>▶ 11.1 11.2 11.6</p> <p>—</p>
<p>9.2 Drawer section for keyboard and mouse, designer door, rear door Height 900 mm IW 6900.410 see page 181</p> 	
<p>9.3 Drawer front, rear panel screw-fastened from the inside Height 900 mm IW 6900.600 see page 181</p>  <p>Note: Component shelf, see from page 1015, drawer tray, see page 1016.</p>	

10 Pedestals

<p>10.1 Worktop base Height 702 mm IW 6900.500 Height 902 mm IW 6900.510 Prepared for attachment of the: Cable duct IW 6903.700 see page 186</p> 	<p>▶ 11.6</p> <p>—</p>
<p>10.2 Pedestal IW 6141.200 see page 290</p> 	
<p>10.3 Cast feet for tower PC IW 6902.920 see page 903</p> 	<p>▶ 11.6</p> <p>—</p>

11 Base/plinth components

<p>11.1 Base/plinth, stationary PC 8800.920 see page 898</p> 	<p>▶ 11.4</p> <p>—</p>
<p>11.2 Base/plinth components, front and rear for TS, solid Height 100 mm TS 8601.600 (RAL 7022) Height 200 mm TS 8602.600 (RAL 7022) see page 893</p> 	<p>▶ 11.3 11.4 11.6</p> <p>— 11.5</p>
<p>11.3 Base/plinth trim panels, side for TS Height 100 mm TS 8601.060 (RAL 7022) Height 200 mm TS 8602.060 (RAL 7022) see page 893</p> 	<p>—</p>
<p>11.4 Base/plinth trim panels with brush strip Height 100 mm TS 8601.610 (RAL 7022) see page 897</p> 	
<p>11.5 Base/plinth trim Height 200 mm PC 8360.920 see page 897</p> 	
<p>11.6 Twin castors PC 4634.500 see page 907</p> 	<p>—</p>

B
1.4

Industrial Workstations

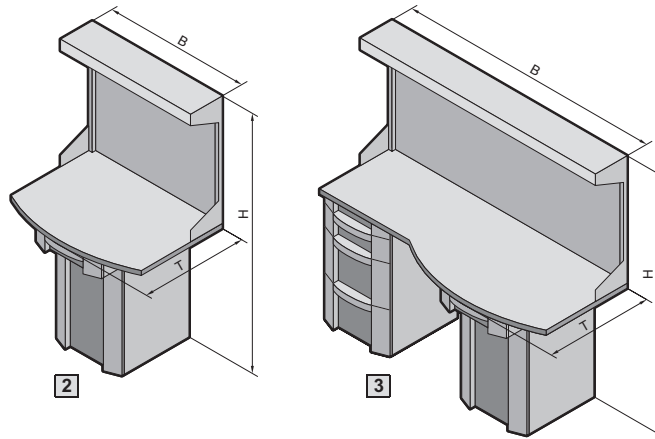

The complete system for use as a testing station in industrial environments (e. g. directly at the machine) where it is necessary to perform testing and process the data electronically. An individual PC system is integrated to perfection.

Benefits:

- Plenty of space to accommodate test equipment
- Easy integration of PCs, monitors, printers etc.
- Integral lighting
- Theft protection

Colour:

RAL 7015/7035/9006

Supply includes

Quality Point L: Enclosure with keyboard drawer section IW 6900.410, see page 181, worktop W/H/D: 1000 x 38 x 895 mm, Quality Point attachment with side system punchings on a 25 mm pitch pattern for the attachment of system accessories (such as punched sections with mounting flanges), workstation light IW, 2 x 36 W, 230 V, 50 Hz.

Supply includes

Quality Point XL: Enclosure with drawer front (left), IW 6900.600, see page 181, enclosure with keyboard drawer section (right), IW 6900.410, see page 181, worktop W/H/D: 2000 x 38 x 895 mm, Quality Point attachment with side system punchings on a 25 mm pitch pattern for the attachment of system accessories (such as punched sections with mounting flanges), workstation light IW (two), 2 x 36 W, 230 V, 50 Hz.

1 Assembly example

2 Quality Point L

3 Quality Point XL

Material:

Enclosure, see page 181, Quality Point attachment, see page 185, worktop, see page 183.

Protection category:

IP 54 to EN 60 529/09.2000, complies with NEMA 12.



	Quality Point L	Quality Point XL	Page
Width (B) mm	1000	2000	
Height (H) mm	2000	2000	
Depth (T) mm	895	895	
Model No. IW	6920.100	6920.200	
Weight (kg)	139	276	

Accessories

	Quality Point L	Quality Point XL	Page
Vertical section	–	6903.010	188
Punched sections with mounting flanges, 17 x 73 mm	8612.090	–	1023
Bracket, locatable for shelves	6902.690	6902.690	1001
Paper removal flap	6903.200	6903.200	1148
Paper tray	6903.000	6903.000	1148
Cable duct	–	6903.700	186
Mounting plate	8614.675	8614.675	984
Component shelf, static installation	8800.900	8800.900	1015
Component shelf, pull-out	6902.960	6902.960	1016
Drawer tray	6902.700	6902.700	1016

Lock systems

Standard double-bit lock insert, may be exchanged for type F lock inserts, see page 956, type B lock cylinder inserts, see page 957, or comfort handle, see page 947 – 948, for front designer door only in conjunction with handle adaptor PC 8611.300, see page 934. Drawer with lock no. 3524 E. Other versions available on request.

Industrial Workstations

Logistic Point

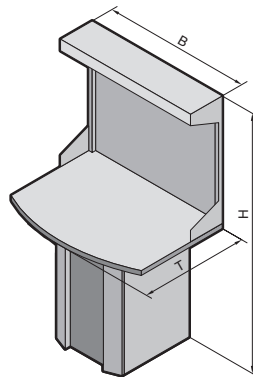

1 Assembly example

The complete system for the input and output of data in the field of company logistics.

Benefits:

- Easy integration of PC, monitor, printer etc.
- Integral lighting
- Theft protection
- Protects against dust and humidity.

Colour:

RAL 7015/7035/9006

Supply includes:

Printer cabinet IW 6900.110, see page 180, built-in module, paper removal flap IW 6903.200, see page 1148, component shelf, pull-out, IW 6902.690, see page 1016, worktop W/H/D: 1000 x 38 x 895 mm prepared for enclosure attachment CP-L Ø 130 mm, IW 6902.130, see page 184, Quality Point attachment L with side system punchings on a 25 mm pitch pattern for the attachment of system accessories (such as punched sections with mounting flanges), see page 185, Optipanel for desk TFT up to 20.1" CP 6380.050, see page 205, workstation light IW, 2 x 36 W, 230 V, 50 Hz, see page 189.

Material:

Enclosure, see page 180, Quality Point attachment L, see page 185, worktop, see page 183.

Protection category:

IP 40 as per EN 60 529/09.2000.



Also required:

For power supply to the workstation light:
Connection cable for infeed, see page 1030.



Accessories:

Optipanel for desk TFT, see page 205.

Note:

Supplied unassembled. All components may also be ordered individually.

	Logistic Point	Page
Width (B) mm	1000	
Height (H) mm	2000	
Depth (T) mm	895	
Model No. IW	6920.000	
Weight (kg)	185.5	
Accessories		
Bracket, locatable for shelves	6902.690	1001
Desktop keyboard IP 65	6446.000	1138
Socket strip	6902.040	1043
Paper removal flap	6903.200	1148
Mounting plate	8614.675	984
Component shelf, static installation	8800.900	1015
Drawer tray	6902.700	1016
Horizontal punched section with mounting flange for Quality Point attachment	8612.090	1023

Lock systems

Standard double-bit lock insert, may be exchanged for type F lock inserts, see page 956, type B lock cylinder inserts, see page 957, or comfort handle, see page 947 – 948, for front designer door only in conjunction with handle adaptor PC 8611.300, see page 934.

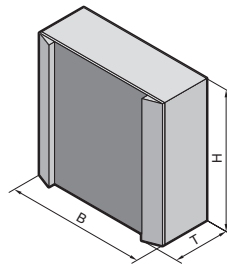

1 Assembly example

Compact enclosure, ready to connect. Standard commercially available tower PCs, up to W/H/D: 250 x 530 x 600 mm (max. 20 kg) may be attached securely to the base screw fastened to the door using the retaining strap supplied loose. The rear interfaces of the PC are readily accessible with the door open. Because the socket strip and fan-and-filter unit are already pre-installed, the enclosure is ready for immediate use.

Roof prepared for mounting

- worktop IW 6902.310/IW 6902.320
- beneath surfaces

Base prepared for mounting

- cast feet IW 6902.920
- on surfaces

Material:

Enclosure: Sheet steel, powder-coated in textured RAL 7035
 Door: Sheet steel, spray-finished in RAL 7015 with fitted design strips of aluminium in RAL 7035

Protection category:

IP 54 to EN 60 529/09.2000, complies with NEMA 12 (in conjunction with connector gland SZ 2400.300/.500 supplied loose)

Supply includes:

Enclosure sealed all round, r/h door hinge, with screw-fastened base on the inside of the tubular door frame to accommodate a tower PC, locked at the side with a fitted cam lock.

Rear panel with two cut-outs for use of the connector gland SZ 2400.300 and .500, supplied loose, connector for power supply, retaining strap to secure the tower PC to the base, left-hand side panel with fitted outlet filter SK 3322.200.

Side panel, right, fitted with:

- Fan-and-filter unit SK 3322.107, technical description see page 690, with door operated switch PS 4315.500
- Supply socket for 230 V power supply
- Socket strip with 3 sockets and overvoltage protection



	Enclosure for tower PC	Page
Width (B) mm	760	
Height (H) mm	760	
Depth (T) mm	300	
Model No. IW	6900.300	
Weight (kg)	55	
Accessories		
Cast feet	6902.920	903
Twin castors	4634.500	907
Worktop without handle	6902.310	184
Worktop with handle	6902.320	184
Enclosure attachment, tilting, base mounting	6902.640	257
Optipanel for TFT monitor 17"	6380.030	205
TFT monitor 17" with safety glass screen	6450.020	1133
Desktop keyboard IP 65	6446.000	1138
Lock systems		
Standard double-bit lock insert may be exchanged for 47 mm lock inserts, type D, see page 956, or plastic handles, type G, see page 954.		

Industrial Workstations

Enclosure with doors

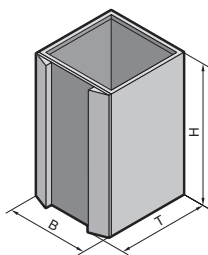

1 Assembly example

Material:

Enclosure, designer door, rear panel, rear door:
Sheet steel, RAL 7035
Glazed door:
Plastic to UL 94-V0, RAL 7035, toughened safety glass 4.0 mm

Protection category:

IP 55 to EN 60 529/09.2000.
Complies with NEMA 12 for IW 6900.110:
IP 40 to EN 60 529/09.2000

Note:

- Other enclosure depths or heights, variable on a 25 mm pitch pattern,
- All IW components as well as system accessories fully assembled ex works are available on request.

For details of what the supply includes,
see page 1197.

Detailed drawing,
see page 1198.

Property rights:

German patent no. 100 13 034
German registered design no. 400 02 325
US patent no. 6,538,876
US design patent no. D 487,730
UK reg. design no. 2 094 499
Japan. reg. design no. 113 95 92
IR reg. design no. DM/053 554 with validity for FR, IT

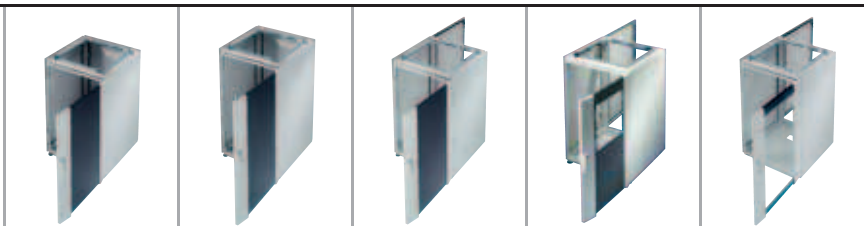

Design	Designer door, rear panel screw-fastened from the inside	Designer door, rear panel screw-fastened from the outside	Designer door, rear door	Designer door, prepared as printer cabinet, rear door	Glazed door, rear door	Page
Width (B) mm	600	600	600	600	600	
Height (H) mm	900	1000	900	900	900	
Depth (T) mm	600	600	600	600	600	
Model No. IW	6900.000	6901.000	6900.100	6900.110	6900.200	
Weight (kg)	54.9	59.8	59.9	59	60.6	

Accessories						
Base/plinth, stationary	8800.920	8800.920	8800.920	8800.920	8800.920	898
Cross member, adjustable	8601.680	8601.680	8601.680	8601.680	8601.680	903
Twin castors	4634.500	4634.500	4634.500	4634.500	4634.500	907
Paper tray	6903.000	6903.000	6903.000	–	–	1148
Paper removal flap	6903.200	6903.200	6903.200	6903.200	–	1148
Handle adaptor for comfort handle	8611.300	8611.300	8611.300	8611.300	6903.170	934
Mounting plate for enclosure width 600 mm	8614.675	8614.675	8614.675	8614.675	8614.675	984
Component shelf, static installation	8800.900	8800.900	8800.900	8800.900	8800.900	1015
Component shelf, pull-out	6902.960	6902.960	6902.960	6902.960	6902.960	1016
Drawer tray	6902.700	6902.700	6902.700	6902.700	6902.700	1016
Drawer extension lock	6902.730	6902.740	6902.730	6902.730	6902.730	1026
Mobile workstations	4641.000	4641.000	4641.000	4641.000	4641.000	1147
Adaptor section 482.6 mm (19")	8613.070	8613.070	8613.070	8613.070	8613.070	1089
Gland plate	Size	2	2	2	2	from 1048
	Qty.	1	1	1	1	

Lock systems
Standard double-bit lock insert, may be exchanged for type F lock inserts, type B lock cylinder inserts, or comfort handle, see from page 947, for designer door and glazed door only in conjunction with handle adaptor PC 8611.300, see page 934.

Enclosure with drawers or worktop

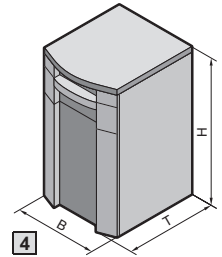
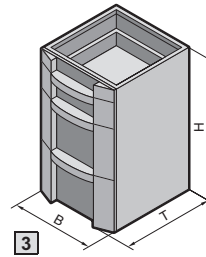
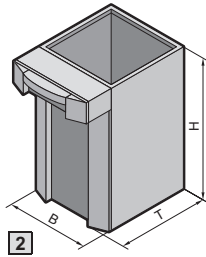

1 Assembly example

Material:

Enclosure, roof, drawer tray, designer door and rear door: Sheet steel, RAL 7035

Worktop:

Chipboard, plastic-laminated on both sides, similar to RAL 7035, with tough plastic edging, similar to RAL 7015

Drawer trim panel:

Plastic, RAL 7035/7015/9006

Protection category:

IP 54 to EN 60 529/09.2000, complies with NEMA 12.





Note:

- Other enclosure depths or heights, variable on a 25 mm pitch pattern,
- All IW components as well as system accessories fully assembled ex works,

- Other drawer combinations,
- Fitted version IW 6901.100 (with worktop) also with other worktops, see page 183, are available on request.

For details of what the supply includes, see page 1197.

Detailed drawing, see page 1198.

					
Design	Drawer section for documents, designer door, rear door	Drawer section for keyboard and mouse, designer door, rear door	Drawer front, rear panel	Enclosure with worktop, keyboard drawer	Page
Width (B) mm	600	600	600	600	
Height (H) mm	900	900	900	1000	
Depth (T) mm	600 (890)	600 (890)	600	645	
Model No. IW	6900.400	6900.410	6900.600	6901.100	
Weight (kg)	73	73	78	91	
Accessories					
Base/plinth, stationary	8800.920	8800.920	8800.920	8800.920	898
Cross member, adjustable	8601.680	8601.680	8601.680	–	903
Twin castors	4634.500	4634.500	4634.500	4634.500	907
Paper removal flap	6903.200	6903.200	6903.200	6903.200	1148
Paper tray	6903.000	6903.000	–	6903.000	1148
Cable gland	6902.770	6902.770	–	6902.770	187
Mounting plate	8614.675	8614.675	–	8614.675	984
Component shelf, static installation	8800.900	8800.900	–	8800.900	1015
Component shelf, pull-out	6902.960	6902.960	–	6902.960	1016
Drawer tray	6902.700	6902.700	–	6902.700	1016
Drawer extension lock	6902.730	6902.730	■ ¹⁾	–	1026
Mobile workstations	4641.000	4641.000	–	–	1147
Adaptor section 482.6 mm (19")	8613.070	8613.070	–	–	1089
Gland plate	Size Qty. 2 1	Size Qty. 2 1	Size Qty. 2 1	Size Qty. 2 1	from 1048
Lock systems					

Standard double-bit lock insert, may be exchanged for type F lock inserts, type B lock cylinder inserts, or comfort handle, see from page 947, for designer door only in conjunction with handle adaptor PC 8611.300, see page 934. Drawer with lock no. 3524 E. Other versions available on request.

¹⁾ Included with the supply.

Industrial Workstations

Roof, worktops



Note:

- Keyboard and front panels for keys integrated into the worktop,
- Worktops in modified sizes,
- All IW components as well as system accessories fully assembled ex works, are available on request.

Detailed drawing,
see page 1199.

Combination options for enclosures/worktops

Width mm	600	600	600	600	600	600	600	
Height mm	900	900	900	900	900	900	1000	
Depth mm	600	600	600	600 (890)	600 (890)	600	600	
Enclosures Model No. IW	6900.000	6900.100	6900.200	6900.400	6900.410	6900.600	6901.000	
Worktop		Page						
6902.000	183	■	■	■	–	–	■	■
6902.100	183	■	■	■	■	■	■	■
6902.110 ¹⁾	183	■	■	■	■	■	■	■
6902.120	184	■	■	■	■	■	■	■
6902.130								
6902.200	183	■	■	■	–	–	■	■
6902.210	183	■	■	■	■	■	■	■
6902.220	183	■	■	■	■	■	■	■
6902.300	183	■	■	■	–	–	■	■
Roof								
6902.400	182	■	■	■	–	–	■	■

¹⁾ Delivery times available on request.

To order worktops in the ESD version, please add the extension .XX8 to the Model No.

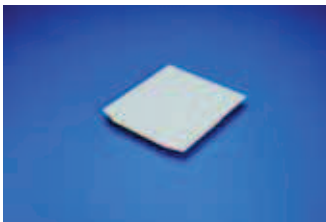

Roof

Folded all-round, with brackets for screw-fastening to the enclosure from the inside.

Material:

Sheet steel 1.5 mm

Surface finish:

Spray-finished in textured RAL 7035

Width (B) mm	600
Height (H) mm	13
Depth (T) mm	640
Weight (kg)	7.4
Model No. IW	6902.400

Worktops

Material and surface finish:

Chipboard, plastic-laminated on both sides, similar to RAL 7035, with tough plastic edging, similar to RAL 7015.

Handle made from aluminium, powder-coated in RAL 9006.

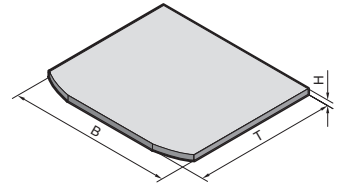

Solid			
	Without handle for enclosure	Without handle for enclosure/worktop base	With handle for enclosure
Design			
Width (B) mm	610	1000	1200
Height (H) mm	38	38	38
Depth (T) mm	645	895	950
Model No. IW	6902.300	6902.100	6902.000
Weight (kg)	11.6	24	34

Solid			
	Without handle for enclosure/worktop base	Without handle for enclosure/worktop base	Without handle for enclosure/worktop base
Design			
Width (B) mm	2000	2000	2000
Height (H) mm	38	38	38
Depth (T) mm	685	685/900	900/685
Model No. IW	6902.200	6902.210	6902.220
Weight (kg)	37	45	45

Prepared for turntable		
Design	Without handle ¹⁾	Page
Width (B) mm	1000	
Height (H) mm	38	
Depth (T) mm	895	
Model No. IW	6902.110²⁾	
Weight (kg)	23	
Accessories		
Turntable	6902.620	187
Spacer plate for monitor housing	6902.630	187

¹⁾ On request also available with handle.

²⁾ Delivery times available on request.

Industrial Workstations

Roof, worktops

Prepared for enclosure attachment
CP-L, Ø 130 mm¹⁾

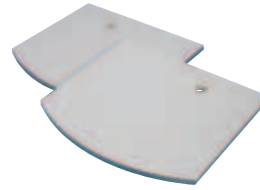

Design	Without handle ²⁾ prepared on left	Without handle ²⁾ prepared on right
Width (B) mm	1000	1000
Height (H) mm	38	38
Depth (T) mm	895	895
Model No. IW	6902.120	6902.130
Weight (kg)	23	23

¹⁾ Hole may be used in conjunction with the adaptor plate for connector grommet IW 6902.660 (see page 1057) for cable entry.

²⁾ On request also available with handle.

Prepared for mounting on
– Pedestal IW
– Enclosure for tower PC
– Worktop attachment

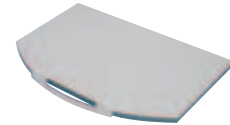
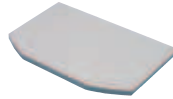

Design	Without handle	With handle
Width (B) mm	950	950
Height (H) mm	38	38
Depth (T) mm	600	658
Model No. IW	6902.310	6902.320
Weight (kg)	16	18



Cable glands
Model No. see page 1057.



Enclosure attachment, tilting
Model No. see page 257.



Socket strip IW
Model No. see page 1043.



**Built-in keyboard 19"/4 U
with integral touchpad**
Model No. see page 1138.



Quality Point attachment

Existing IW solutions may be upgraded to a complete testing station. Side punched profile on a 25 mm pitch pattern for the attachment of system accessories (e. g. TS punched section with mounting flange 17 x 73 mm for inner mounting level, see page 993). Projection with integral glare shield prepared for mounting of workstation light 6903.080 (1 x for IW 6920.110/2 x for IW 6920.210).

Material:

Sheet steel, spray-finished

Colour:

RAL 7035

Supply includes:

Assembly parts for mounting on worktops (see page 182).

Note:

The Quality Point attachment may be mounted directly on the wall if necessary. Shelf to finish off at the bottom available on request.



	Quality Point attachment L	Quality Point attachment XL	Page
Width (B) mm	1000	2000	
Height (H) mm	960	960	
Model No. IW	6920.110	6920.210	
Weight (kg)	34	64	
Accessories			
Workstation light	6903.080	6903.080	189
Vertical section	–	6903.010	188
Display board with wall bracket	6013.100	6013.100	1118
Utility shelf 220 mm wide	6514.110	6514.110	1123
Utility shelf 450 mm wide	6514.100	6514.100	1123
Mounting plates, locatable	8612.400	8612.400	1003
Metal multi-tooth screws BZ 5.5 x 13 mm	2486.500	2486.500	1011
Bracket, locatable, for shelves	6902.690	6902.690	1001
TS punched section with mounting flange, 17 x 73 mm	8612.090	–	993

Monitor housing

For protected accommodation of monitors up to 17" or 21" screen diagonal.

Material:

Enclosure, rear door and component shelf:
1.5 mm sheet steel

Designer door: Vertical plastic decorative trim panels to UL 94-V0

Pane: Toughened safety glass 4.0 mm

Surface finish:

Enclosure and rear door: Textured RAL 7035
Designer door: Decorative trim panels RAL 7035, screen-printed mask on glass pane RAL 7015
Component shelf: RAL 7015

Protection category:

IP 55 to EN 60 529/09.2000,
complies with NEMA 12.

Supply includes:

Front designer door with internal lock, unlatched behind the rear door via a lever with Bowden cable.

Rear door with standard double-bit lock insert, may be exchanged for 27 mm lock inserts, type A, or lock cylinder inserts, type B, see page 956/957, and for Ergoform-S lock system, see page 953.

Enclosure with cut-out at the bottom and reinforcement for mounting
– on worktops, prepared for turntable, see page 183,
– on spacer plate for monitor housing, see page 187.

Base prepared for the mounting of feet for desk-top use IW 6902.610.

Fitted component shelf, slotted, height-adjustable on a 25 mm pitch pattern, prepared for mounting fan expansion kit DK 7980.000, see page 703, and a socket strip, 482.6 mm (19") long, see page 1038.

	Monitor housing for screen 17"	Monitor housing for screen 21"
Width (B) mm	600	600
Height (H) mm	600	600
Depth (T) mm	500	600
Model No. IW	6902.510	6902.500
Weight (kg)	38.5	42.5

Delivery times available on request.



Accessories:

Feet for desk-top use, see page 186.

Spacer plate for monitor housing, see page 187.

Turntable for monitor housing, see page 187.

Detailed drawing,

see page 1198.



Accessories

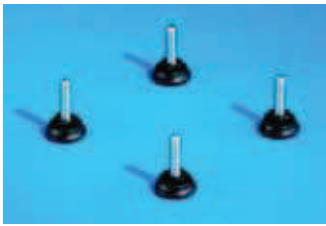

Feet

for monitor housing

Thread length 39 mm.

Max. static load per foot:
300 kg

Thread	Packs of	Model No. IW
M8	4	6902.610

Delivery times available on request.



Worktop base

For mounting instead of an enclosure when using a wide worktop. Prepared for attachment of cable duct IW 6903.700.

Material:

Steel, spray-finished

Colour:

RAL 7035

Supply includes:

Levelling feet and screws for the attachment of a worktop.

Note:

For reasons of stability, the worktop base should always be fitted in conjunction with the cable duct IW 6903.700 or other cross-braces supplied by the customer.

Height mm	Packs of	Model No. IW
702	1	6900.500
902	1	6900.510

+ Accessories:

Cable duct, see page 186.
Worktops, see page 182.

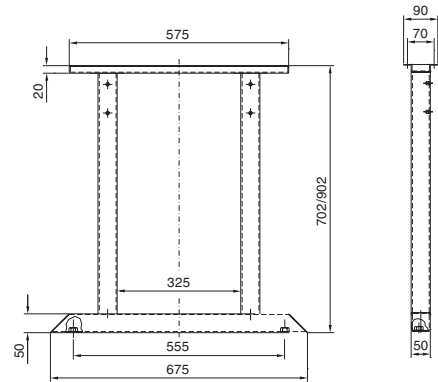

Cable duct

With punchings for the attachment of cable ties and prepared for the installation of a socket strip. Extension to any length may be achieved by baying several cable ducts together.

Installation:

- Beneath worktops IW
- Beneath surfaces
- Between IW enclosures
- Between IW worktop bases

Material:

Sheet steel, spray-finished

Colour:

Textured RAL 7035

Length mm	Packs of	Model No. IW
760	1	6903.700

+ Accessories:

Cable tie for fast assembly SZ 2597.000, see page 1066.
Socket strip, see page 1043.



Adaptor plate

for connector gland, see page 1057.



Cable gland

for IW worktops

To fit drilled holes 60 mm. For the entry of cables with pre-assembled connectors, the rotating flap and cover are easily removed.

Material:

Plastic

Colour:

RAL 7035



Packs of	Model No. IW
1	6902.770

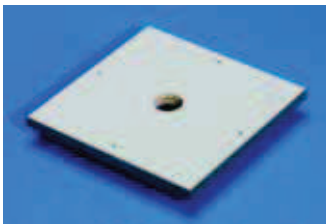
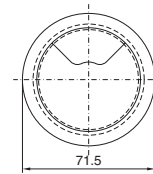
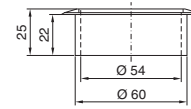

Spacer plate

for monitor housing

Creates distance from the worktop to prevent damage to the mouse and keyboard.

Material:

Chipboard, plastic-laminated on both sides, similar to RAL 7035, with tough plastic edging, similar to RAL 7015.

Note:

If a wider gap is required, 2 spacer plates may also be screw-fastened on top of one another.

- Other sizes
- Other drilled holes available upon request.

Width mm	Depth mm	Height mm	Model No. IW
400	400	25	6902.630

Delivery times available on request.

+ Accessories:

Turntable, see page 187.

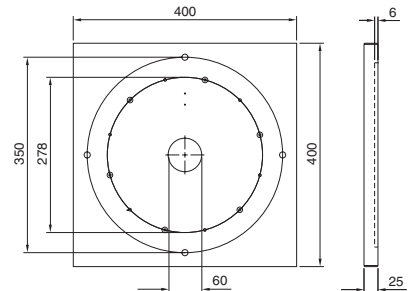

Turntable

for spacer plate IW 6902.630

Diameter: 328 mm

Height: 14 mm

Load capacity: 300 kg, vertical

Rotation range:

350°, may be limited to 90°, 180° and 270° by 3 end stops.

Material:

Cast aluminium, powder-coated

Colour:

Black

Supply includes:

Assembly parts for screw-fastening on both sides.

Packs of	Model No. IW
1	6902.620

Delivery times available on request.

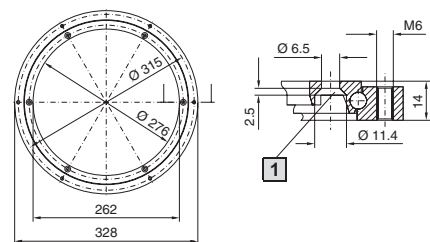

1 For csk screw M6



Optipanel

A stylish enclosure of extruded aluminium section. In installation depths 50, 100 and 150 mm, the width and height are sized to your specified panels.

Standard sizes are available off the shelf for TFT monitors 15" and 17" with safety glass or touchscreen, and also for conventional desktop TFTs up to 20.1", see page 205.

Full information on the Optipanel from page 204.



Compact Panel

For slimline and compact panels, or as a visually appealing switch housing.

Thanks to the tiltable enclosure attachment IW 6902.670, see page 243, may also be fitted via support arm system CP-L on worktops prepared for enclosure attachment CP-L, Ø 130 mm, see page 256

Full information on the Compact Panel from page 231.



Comfort Panel

Choose from 11 installation depths in a number of different variants. Whether screw-fastened or with a flat front frame, hinged, the Comfort Panel will always adapt to suit your requirements. An all-round soft profile reduces the risk of injury. Simply compile your individual Comfort Panel or use the standard sizes, available off the shelf for TFT monitors 15" and 17".

Full information on the Comfort Panel from page 192.



Vertical section

For subdividing the vertical surface of the Quality Point XL. By locating e. g. TS punched sections with mounting flanges (17 x 73 mm) into the TS punched profile, the simple mounting of system accessories (such as CP utility shelves) is facilitated.

Length: 950 mm.

Material:
Sheet steel, 1.5 mm

Colour:
RAL 7035

Supply includes:
Assembly parts.

Support arm system CP-L

Using support section CP-L, operating housings may be positioned in a rotatable and swivelling configuration depending on the respective ergonomic conditions, see from page 250.

Packs of	Model No. IW
1	6903.010

Accessories:

TS punched sections with mounting flange 17 x 73 mm, see page 993, Utility shelves CP, see page 1123, Snap-on nuts, see page 1005.

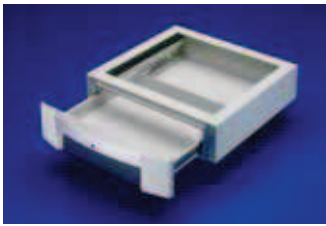

Drawer

for documents

Under-mounting

For mounting beneath

- Worktop
- Adequately large surfaces

For test equipment, pens, production documents etc. Lockable, lock cylinder insert, lock no. 3524 E.

Material:

Drawer housing: Sheet steel
Front: Plastic to UL 94-V0

Colour:

RAL 7035,
front surface RAL 7015,
handle strip RAL 9006.

Protection category:

IP 55 to EN 60 529/09.2000,
complies with NEMA 12.

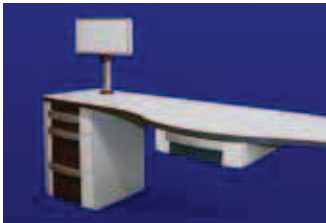

Packs of	Model No. IW
1	6902.900

Delivery times available on request.



Accessories:

Cross members for drawer tray,
see page 1016.



Drawer

for keyboard and mouse

Under-mounting

For mounting beneath

- Worktop
- Adequately large surfaces

Lockable with mousepad support, may be extended to the left or right, and cable support for safe, pinch-free cable routing. Cable entry with brush strip.

Material:

Drawer housing: Sheet steel
Front: Plastic to UL 94-V0

Colour:

RAL 7035,
front surface RAL 7015,
handle strip RAL 9006.

Protection category:

IP 55 to EN 60 529/09.2000,
complies with NEMA 12.



Packs of	Model No. IW
1	6902.910



Workstation light

For IW

For mounting on the IW Quality Point attachment. The workstation light ensures optimum, glare-free illumination of the workstation.

Technical specifications:

2 compact fluorescent lamps (36 W, 230 V, 50 Hz)
TC-L 36, base/plinth 2 GL. With switch, sockets and connectors for power infeed and through-wiring.

Supply includes:

Assembly parts.



Width mm	Height mm	Depth mm	Model No. IW
900	135	60	6903.080



Also required:

Connection accessories,
see page 1030.