

General Specifications

EJX118A Diaphragm Sealed Differential Pressure Transmitter



GS 01C25H01-01E

[Style: S2]

Diaphragm seals are used to prevent process medium from entering directly into the pressure-sensing assembly of the differential pressure transmitter, they are connected to the transmitter using capillaries filled with fill fluid.

EJX118A Diaphragm Sealed Differential Pressure Transmitters can be used to measure liquid, gas, or steam flow, as well as liquid level, density, and pressure. EJX118A outputs a 4 to 20 mA DC signal corresponding to the measured differential pressure. Its highly accurate and stable sensor can also measure the static pressure which can be shown on the integral indicator or remotely monitored via BRAIN or HART communications. Other key features include quick response, remote set-up using communications, and diagnostics and optional status output for pressure high/low alarm. The multi-sensing technology provides the advanced diagnostic function to detect such abnormality as an impulse line blockage.

FOUNDATION Fieldbus protocol type is also available. All EJX series models in their standard configuration, with the exception of the Fieldbus type, are certified by TÜV as complying with SIL 2 for safety requirement.



■ STANDARD SPECIFICATIONS

Refer to GS 01C25T02-01E for Fieldbus communication type marked with “◇.”

□ SPAN AND RANGE LIMITS

Measurement Span/Range	kPa	inH ₂ O/(D1)	mbar/(D3)	mmH ₂ O/(D4)
M Span	2 to 100	8 to 400	20 to 1000	200 to 10000
M Range	-100 to 100	-400 to 400	-1000 to 1000	-10000 to 10000
H Span	10 to 500	40 to 2000	100 to 5000	0.1 to 5 kgf/cm ²
H Range	-500 to 500	-2000 to 2000	-5000 to 5000	-5 to 5 kgf/cm ²

T01E.EPS

□ PERFORMANCE SPECIFICATIONS

Zero-based calibrated span, linear output, wetted parts material code SW for 3-inch flange flush type, fill fluid code B, and capillary length of 5 m.

For Fieldbus communication type, use calibrated range instead of span in the following specifications.

Specification Conformance

EJX series ensures specification conformance to at least $\pm 3\sigma$.

Reference Accuracy of Calibrated Span

(includes terminal-based linearity, hysteresis, and repeatability)

Measurement span	H	
Reference accuracy	X \leq span	$\pm 0.15\%$ of Span
	X > span	$\pm(0.085+0.013 \text{ URL}/\text{span})\%$ of Span
X	100 kPa (400 inH ₂ O)	
URL (upper range limit)	500 kPa (2000 inH ₂ O)	

T02E.EPS

Measurement span		M
Reference accuracy	X \leq span	$\pm 0.15\%$ of Span
	X > span	$\pm(0.02+0.013 \text{ URL}/\text{span})\%$ of Span
X		10 kPa (40 inH ₂ O)
URL (upper range limit)		100 kPa (400 inH ₂ O)

T03E.EPS

Square Root Output Accuracy

The square root accuracy is a percent of flow span.

Output	Accuracy
50% or Greater	Same as reference accuracy
50% to Dropout point	$\frac{\text{Reference accuracy} \times 50}{\text{Square root output}} (\%)$

T04E.EPS

Ambient Temperature Effects per 28°C (50°F) Change

Capsule	Effect
M and H	$\pm(0.25\% \text{ Span} + 0.06\% \text{ URL})$

Static Pressure Effects per 0.69 MPa (100 psi) Change

Span Effects
M and H capsules
 $\pm 0.02\%$ of span

Effect on Zero
M and H capsules
 $\pm 0.014\%$ of URL

Power Supply Effects (Output signal code D and E)
 ±0.005% per Volt (from 21.6 to 32 V DC, 350 Ω)

Response Time (Differential pressure) “◇”
 M and H capsule: 200 msec (approximate value at normal temperature)
 When software damping is set to zero and including dead time of 45 msec (nominal)

Static Pressure Signal Range and Accuracy (For monitoring via communication or on indicator. Includes terminal-based linearity, hysteresis, and repeatability)

Range

Upper Range Value and Lower Range Value of the static pressure can be set in the range between 0 and Maximum Working Pressure (MWP*). The upper range value must be greater than the lower range value. Minimum setting span is 0.5 MPa (73 psi).

*: Maximum Working Pressure (MWP) is within flange rating pressure.

Accuracy

Absolute Pressure

1 MPa or higher : ±0.2% of span
 Less than 1 MPa: ±0.2%×(1 MPa/span) of span

Gauge Pressure Reference

Gauge pressure reference is 1013 hPa (1 atm)
 Note : Gauge pressure variable is based on the above fixed reference and thus subject to be affected by the change of atmospheric pressure.

□ **FUNCTIONAL SPECIFICATIONS**

Output “◇”

Two wire 4 to 20 mA DC output with digital communications, linear or square root programmable. BRAIN or HART FSK protocol are superimposed on the 4 to 20 mA signal.
 Output range: 3.6 mA to 21.6 mA
 Output limits conform to NAMUR NE43 can be pre-set by option code C2 or C3.

Failure Alarm (Output signal code D and E)

Output status at CPU failure and hardware error;
 Up-scale: 110%, 21.6 mA DC or more (standard)
 Down-scale: -5%, 3.2 mA DC or less
 Analog output status at process abnormality (Option code /DG6);
 The result of process abnormality detected by the advanced diagnostic function can be reflected to an analog alert status. The following three setting modes are available.

		Mode		
		Burnout	Fall back	Off
Standard		110 %, 21.6mA or more	Holds to a specified value within the output range from 3.6mA to 21.6mA	Not Available (normal output)
Option Code	/C1	-2.5%, 3.6mA or less		
	/C2	-1.25%, 3.8mA or less		
	/C3	103.1%, 20.5mA or more		

T15E.EPS

Damping Time Constant (1st order)

Amplifier damping time constant is adjustable from 0.00 to 100.00 sec by software and added to response time.

Note: For BRAIN protocol type, when amplifier software damping is set to less than 0.5 sec, communication may occasionally be unavailable during the operation, especially while output changes dynamically. The default setting of damping ensures stable communication.

Update Period “◇”

Differential pressure: 45 ms
 Static pressure: 360 ms

Zero Adjustment Limits

Zero can be fully elevated or suppressed, within the lower and upper range limits of the capsule.

External Zero Adjustment

External zero is continuously adjustable with 0.01% incremental resolution of span. Re-range can be done locally using the digital indicator with range-setting switch.

Integral Indicator (LCD display, optional) “◇”

5-digit numerical display, 6-digit unit display and bar graph.
 The indicator is configurable to display one or up to four of the following variables periodically.;
 Measured differential pressure, differential pressure in %, scaled differential pressure, measured static pressure. See also “Factory Setting.”

Self Diagnostics

CPU failure, hardware failure, configuration error, process alarm for differential pressure, static pressure or capsule temperature.
 User-configurable process high/low alarm for differential pressure and static pressure is also available, and its status can be output when optional status output is specified.

Advanced Diagnostics (optional) “◇”

Applicable for Output signal code E and F.
 • Impulse line blockage detection
 The impulse line condition can be calculated and detected by extracting the fluctuation component from the differential pressure and static pressure signals. The EJX118A detects the impulse line abnormality particularly which side of impulse line is plugged.

Signal Characterizer (Output signal code D and E)

User-configurable 10-segment signal characterizer for 4 to 20 mA output.

Capillary Fill Fluid Density Compensation (Output signal code D and E)

Compensation of the zero shift by the ambient temperature effect on the capillary tube.

Status Output

(optional, output signal code D and E)

One transistor contact output (sink type) to output the status of user configurable high/low alarm for differential pressure/static pressure.
 Contact rating: 10.5 to 30 V DC, 120 mA DC max.
 Refer to ‘Terminal Configuration’ and ‘Wiring Example for Analog Output and Status Output.’

SIL Certification

EJX series transmitters except Fieldbus communication type are certified by TÜV in compliance with the following standards;
IEC 61508: 2000; Part1 to Part 7
Functional Safety of Electrical/electronic/programmable electronic related systems; SIL 2 capability for single transmitter use, SIL 3 capability for dual transmitter use.

□ NORMAL OPERATING CONDITION

(Optional features or approval codes may affect limits.)

Ambient Temperature Limits

–40 to 60°C (–40 to 140°F)
–30 to 60°C (–22 to 140°F) with LCD display
(Note : The ambient temperature limits must be within the fill fluid operating temperature range, see table 1.)

Process Temperature Limits

See table 1.

Ambient Humidity Limits

0 to 100% RH

Working Pressure Limits

See table 1.
For atmospheric pressure or below, see figure 1-1 and 1-2.

Table 1. Process temperature, Ambient temperature, and Working pressure

	Code	Process temperature*1	Ambient temperature*2	Working pressure	Specific gravity*3
Silicone oil (general use)	A	-10 to 250°C *4 (14 to 482°F)	-10 to 60°C (14 to 140°F)	2.7 kPa abs (0.38 psi abs) to flange rating pressure	1.07
Silicone oil (general use)	B	-30 to 180°C (-22 to 356°F)	-15 to 60°C (5 to 140°F)		0.94
Silicone oil (high temperature use)	C	10 to 310°C (50 to 590°F)	10 to 60°C (50 to 140°F)		1.09
Fluorinated oil (oil-prohibited use)	D	-20 to 120°C (-4 to 248°F)	-10 to 60°C (14 to 140°F)	51 kPa abs (7.4 psi abs) to flange rating pressure	1.90 to 1.92
Ethylene glycol (low temperature use)	E	-50 to 100°C (-58 to 212°F)	-40 to 60°C (-40 to 140°F)	100 kPa abs (atmospheric pressure) to flange pressure rating	1.09

T05E.EPS

*1: See figure 1-1 and 1-2 'Working Pressure and Process Temperature.'

*2: This ambient temperature is the transmitter ambient temperature.

*3: Approximate values at a temperature of 25°C (77°F)

*4: In case of wetted parts material code TW (Tantalum), process temperature limit is up to 200°C (392°F).

Note: The differential pressure transmitter should be installed at least 600 mm below the high pressure (HP) process connection. However, this value (600 mm) may be affected by ambient temperature, operating pressure, fill fluid or material of the wetted diaphragm.

Contact YOKOGAWA when the transmitter can not be installed at least 600 mm below the HP process connection.

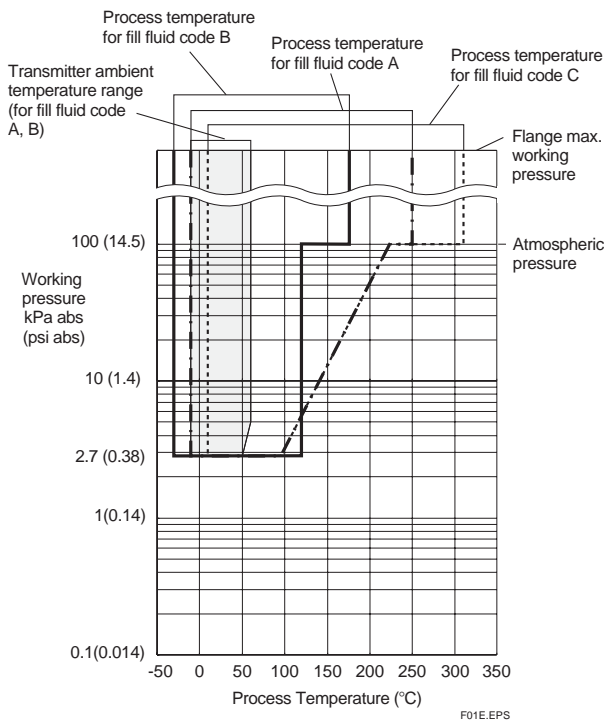

F01E.EPS

**Figure 1-1. Working Pressure and Process Temperature
(Fill fluid : silicone oil for general and high
temperature use)**

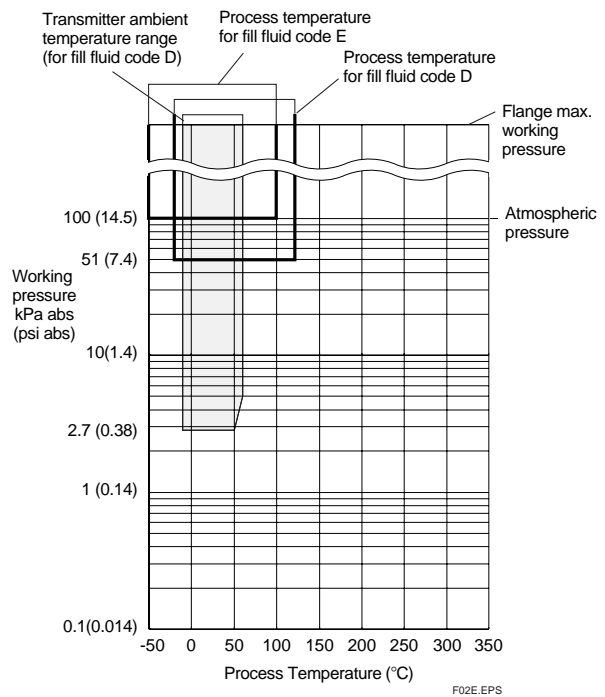

F02E.EPS

**Figure 1-2. Working Pressure and Process Temperature
(Fill fluid : fluorinated oil for oil-prohibited use and
ethylene glycol for low temperature use)**

Supply & Load Requirements

(Output signal code D and E. Optional features or approval codes may affect electrical requirements.)

With 24 V DC supply, up to a 550 Ω load can be used. See graph below.

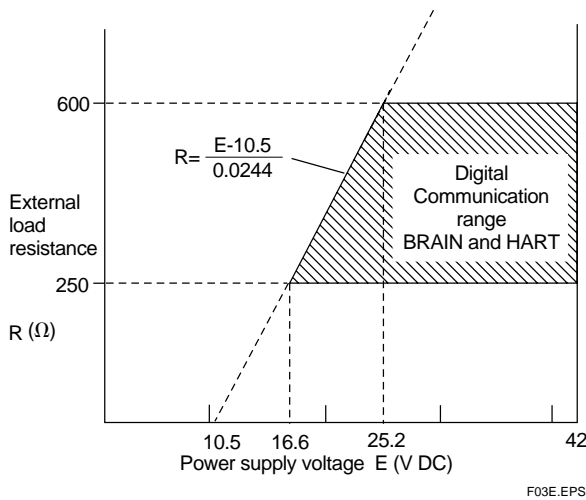

Figure 2. Relationship Between Power Supply Voltage and External Load Resistance

Supply Voltage “◇”

10.5 to 42 V DC for general use and flameproof type.
 10.5 to 32 V DC for lightning protector (option code /A).
 10.5 to 30 V DC for intrinsically safe, type n, or non-incendive.

Minimum voltage limited at 16.6 V DC for digital communications, BRAIN and HART

Load (Output signal code D and E)

0 to 1290 Ω for operation
 250 to 600 Ω for digital communication

Communication Requirements “◇”

(Approval codes may affect electrical requirements.)

BRAIN

Communication Distance

Up to 2 km (1.25 miles) when using CEV polyethylene-insulated PVC-sheathed cables. Communication distance varies depending on type of cable used.

Load Capacitance

0.22 μF or less

Load Inductance

3.3 mH or less

Input Impedance of communicating device

10 kΩ or more at 2.4 kHz.

EMC Conformity Standards CE , N200

EN61326-1 Class A, Table2 (For use in industrial locations)
 EN61326-2-3

European Pressure Equipment Directive 97/23/EC

Sound Engineering Practice

PHYSICAL SPECIFICATIONS

Process connections

See the following table.

Table 2. Flange size and rating

Process connection style	Size	Flange
Flush type	3-inch	JIS 10K, 20K, 40K
	2-inch	ANSI Class 150, 300, 600
	1½-inch*	JPI Class 150, 300, 600 DIN PN10/16, 25/40, 64
Extended type	4-inch	JIS 10K, 20K
	3-inch	ANSI Class 150, 300 JPI Class 150, 300 DIN PN10/16, 25/40
Combination type (Extended and Flush)	High pressure side: 4-inch	JIS 10K, 20K
	Low pressure side: 3-inch	ANSI Class 150, 300 JPI Class 150, 300 DIN PN10/16, 25/40

*: Flushing connection rings are always attached.

T06E.EPS

Gasket Contact Surface

See the following table.

Table 3. Gasket contact surface

Flange	JIS/JPI/DIN		ANSI	
	SW, SE, SY	HW, TW, UW	SW, SE, SY	HW, TW, UW
Wetted parts material code				
Gasket contact Surface	Serration*1	—	●	—
	Flat (No serration)	●	●	●

●: Applicable, —: Not applicable

*1:ANSI B16.5

T07E.EPS

Electrical Connections

See “MODEL AND SPECIFICATIONS.”

Transmitter Mounting

2-inch pipe mounting

Wetted Parts Material

Diaphragm seal

Diaphragm and other wetted parts;
 Refer to “MODEL AND SUFFIX CODES.”

Flushing connection ring (optional)

Ring and Vent / Drain plugs
 Refer to “MODEL AND SUFFIX CODES.”
 (Spiral) gasket for transmitter side
 316SST (Hoop), PTFE Teflon (Filler)

Non-wetted Parts Material

Transmitter body section:

Cover flange

ASTM CF-8M

Cover flange bolting

ASTM-B7 carbon steel, 316L SST stainless steel, or ASTM grade 660 stainless steel

Housing

Low copper cast aluminum alloy with polyurethane, mint-green paint (Munsell 5.6BG 3.3/2.9 or its equivalent) or ASTM CF-8M stainless steel

Degrees of Protection

IP67, NEMA4X, JIS C0920

Name plate and tag

304 SST, 316 SST (optional)

Diaphragm seal section:

Process Flange

JIS S25C, JIS SUS304, or JIS SUS316

Capillary tube

JIS SUS316

Protection tube

JIS SUS304 PVC-sheathed

(Max. operating temperature of PVC, 100°C (212°F))

Fill fluid

See table 1.

Weight

Flush type: 16.1 kg (35.5 lbs)

(3-inch ANSI Class150 flange, capillary length 5 m; without integral indicator and mounting bracket.)

Extended type: 21.7 kg (47.9 lbs)

(4-inch ANSI Class150 flange, extension length (X₂)=100 mm, capillary length 5 m; without integral indicator and mounting bracket.)

Combination type: 18.9 kg (41.7 lbs)

(4-inch and 3-inch ANSI Class150 flange, extension length (X₂) =100 mm, capillary length 5 m; without integral indicator and mounting bracket.)

Add 1.5kg (3.3lb) for Amplifier housing code 2.

< Related Instruments > “◇”

Power Distributor: Refer to GS 01B04T01-02E or GS 01B04T02-02E

BRAIN TERMINAL: Refer to GS 01C00A11-00E

< Reference >

1. Teflon; Trademark of E.I. DuPont de Nemours & Co.
2. Hastelloy; Trademark of Haynes International Inc.
3. HART; Trademark of the HART Communication Foundation.
4. FOUNDATION Fieldbus; Trademark of Fieldbus Foundation.

Other company names and product names used in this material are registered trademarks or trademarks of their respective owners.

II. Diaphragm seal section (Flush type)

● Process connection size: 3-inch (80mm) / 2-inch (50mm)

EJX118A-□□□□-□□□□-W□□³/₂□□□□-□□□□

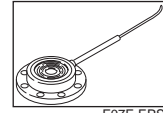

F07E.EPS

Model	Suffix codes	Description																		
EJX118A	-□□□□-□□□□-.....	Transmitter body section (I)																		
Process connection style	-W.....	Flush type																		
Flange rating	J1..... JIS 10K J2..... JIS 20K J4..... JIS 40K A1..... ANSI class 150 P1..... JPI class 150 A2..... ANSI class 300 P2..... JPI class 300 A4..... ANSI class 600 P4..... JPI class 600 D2..... DIN PN10/16 D4..... DIN PN25/40 D5..... DIN PN64																			
Process connection size (Process flange size)	3..... 3-inch (80 mm) 2..... 2-inch (50 mm)																			
Flange material	☆ A..... JIS S25C ☆ B..... 304 SST *11 C..... 316 SST *11																			
Gasket contact surface*1	1..... Serration (for ANSI flange with wetted parts material SW only) 2..... Flat (no serration)																			
Wetted parts material*10	<table border="1"> <thead> <tr> <th></th> <th>[Diaphragm]</th> <th>[Others]</th> </tr> </thead> <tbody> <tr> <td>SW.....</td> <td>316L SST #</td> <td>316L SST #</td> </tr> <tr> <td>HW.....</td> <td>Hastelloy C-276 *9#</td> <td>Hastelloy C-276 *9#</td> </tr> <tr> <td>TW.....</td> <td>Tantalum *7</td> <td>Tantalum *7</td> </tr> <tr> <td>UW.....</td> <td>Titanium</td> <td>Titanium (for 3-inch process flange only)</td> </tr> </tbody> </table>		[Diaphragm]	[Others]	SW.....	316L SST #	316L SST #	HW.....	Hastelloy C-276 *9#	Hastelloy C-276 *9#	TW.....	Tantalum *7	Tantalum *7	UW.....	Titanium	Titanium (for 3-inch process flange only)				
	[Diaphragm]	[Others]																		
SW.....	316L SST #	316L SST #																		
HW.....	Hastelloy C-276 *9#	Hastelloy C-276 *9#																		
TW.....	Tantalum *7	Tantalum *7																		
UW.....	Titanium	Titanium (for 3-inch process flange only)																		
Flushing connection ring*2	☆ 0..... [Ring] None 1..... Straight type 2..... Straight type	[Drain/Vent plugs] R 1/4 connections [Material] 316 SST # 1/4 NPT connections 316 SST #																		
Extension	0..... None																			
Fill fluid*5	☆ -A..... For general use (silicone oil)*3 ☆ -B..... For general use (silicone oil) -C..... For high temperature use (silicone oil)*4 *7 -D..... For oil-prohibited use (fluorinated oil)*5 -E..... For low temperature use (ethylene glycol)	<table border="1"> <thead> <tr> <th></th> <th>[Process temperature]</th> <th>[Ambient temperature]</th> </tr> </thead> <tbody> <tr> <td>-A</td> <td>-10 to 250°C</td> <td>-10 to 60°C</td> </tr> <tr> <td>-B</td> <td>-30 to 180°C</td> <td>-15 to 60°C</td> </tr> <tr> <td>-C</td> <td>10 to 310°C</td> <td>10 to 60°C</td> </tr> <tr> <td>-D</td> <td>-20 to 120°C</td> <td>-10 to 60°C</td> </tr> <tr> <td>-E</td> <td>-50 to 100°C</td> <td>-40 to 60°C</td> </tr> </tbody> </table>		[Process temperature]	[Ambient temperature]	-A	-10 to 250°C	-10 to 60°C	-B	-30 to 180°C	-15 to 60°C	-C	10 to 310°C	10 to 60°C	-D	-20 to 120°C	-10 to 60°C	-E	-50 to 100°C	-40 to 60°C
	[Process temperature]	[Ambient temperature]																		
-A	-10 to 250°C	-10 to 60°C																		
-B	-30 to 180°C	-15 to 60°C																		
-C	10 to 310°C	10 to 60°C																		
-D	-20 to 120°C	-10 to 60°C																		
-E	-50 to 100°C	-40 to 60°C																		
Capillary connection	A.....	Side of diaphragm seal unit																		
—	2.....	Always 2																		
Capillary length*6	1..... 1 m 2..... 2 m 3..... 3 m 4..... 4 m 5..... 5 m	6..... 6 m 7..... 7 m 8..... 8 m 9..... 9 m A..... 10 m																		
Option codes		/□ Optional specification																		

The "☆" marks indicate the most typical selection for each specification. Example: EJX118A-DMSCG-912EN-WA13B1SW00-BA25/□

T09E.EPS

*1: See table 3 'Gasket contact surface' on page 5.

*2: When specified flushing connection ring code 1 or 2, exclusive gaskets are provided for transmitter side.

*3: In case of wetted parts material code TW (Tantalum), the process temperature limit is -10 to 200°C.

*4: Wetted parts material code TW (Tantalum) cannot be applied.

*5: Even in case where fill fluid code D (fluorinated oil) is selected, if degrease cleansing treatment or both degrease cleansing and dehydrating treatment for the wetted parts is required, specify option code K1 or K5.

*6: In case of wetted parts material code HW (Hastelloy C) and TW (Tantalum) for 2-inch process flange, specify capillary length from 1 to 5m.

*7: Not applicable for flushing connection ring code 1 and 2.

*8: Not applicable for gasket contact surface code 1.

*9: Hastelloy C-276 or N10276.

*10: Users must consider the characteristics of selected wetted parts material and the influence of process fluids. The use of inappropriate materials can result in the leakage of corrosive process fluids and cause injury to personnel and/or damage to plant facilities. It is also possible that the diaphragm itself can be damaged and that material from the broken diaphragm and the fill fluid can contaminate the user's process fluids.

Be very careful with highly corrosive process fluids such as hydrochloric acid, sulfuric acid, hydrogen sulfide, sodium hypochlorite, and high-temperature steam (150°C [302°F] or above). Contact Yokogawa for detailed information of the wetted parts material.

*11: Forged version of the material may be used.

The '#' marks indicate the construction materials conform to NACE material recommendations per MR01-75. For the use of 316 SST material, there may be certain limitations for pressure and temperature. Please refer to NACE standards for details.

II. Diaphragm seal section (Flush type)

● Process connection size: 1 1/2-inch (40 mm)

EJX118A-□□□□-□□□□-W 8 □□□□□□□□□□

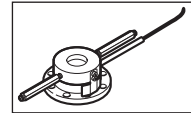

F08E.EPS

Model	Suffix codes	Description
EJX118A	-□□□□□□-□□□□□□-.....	Transmitter body section (I)
Process connection style	-W	Flush type
Flange rating	J1	JIS 10K
	J2	JIS 20K
	J4	JIS 40K
	A1	ANSI class 150
	A2	ANSI class 300
	A4	ANSI class 600
	P1	JPI class 150
	P2	JPI class 300
	P4	JPI class 600
Process connection size (Process flange size)	8	1 1/2-inch (40 mm)
Flange material	☆ A	JIS S25C
	B	304 SST *6
	C	316 SST *6
Gasket contact surface*1	1	Serration (for ANSI flange only)
	2	Flat (no serration)
Wetted parts material*5	SW	[Diaphragm] [Others] 316L SST # 316L SST #
Flushing connection ring*2	3	[Ring] [Drain/Vent plugs] [Material] Reducer type R 1/4 connections *4 316 SST #
	4	Reducer type 1/4 NPT connections 316 SST #
Extension	0	None
Fill fluid	☆ -A	For general use (silicone oil) [Process temperature] [Ambient temperature] -10 to 250°C -10 to 60°C
	-B	For general use (silicone oil) -30 to 180°C -15 to 60°C
	-D	For oil-prohibited use (fluorinated oil)*3 -20 to 120°C -10 to 60°C
	-E	For low temperature use (ethylene glycol) -50 to 100°C -40 to 60°C
Capillary connection	A	Side of diaphragm seal unit
—	2	Always 2
Capillary length	1	1 m
	2	2 m
	3	3 m
	4	4 m
	5	5 m
	6	6 m
	7	7 m
	8	8 m
	9	9 m
	A	10 m
Option codes		<input type="checkbox"/> Optional specification

T10E.EPS

The "☆" marks indicate the most typical selection for each specification. Example: EJX118A-DMSCG-912EN-WA18B1SW40-BA25/□

*1: See table 3 'Gasket contact surface' on page 5.

*2: When specified flushing connection ring code 3 or 4, exclusive gaskets are provided for transmitter side.

*3: Even in case where fill fluid code D (fluorinated oil) is selected, if degrease cleansing treatment or both degrease cleansing and dehydrating treatment for the wetted parts is required, specify option code K1 or K5.

*4: Not applicable for gasket contact surface code 1.

*5: ⚠ Users must consider the characteristics of selected wetted parts material and the influence of process fluids. The use of inappropriate materials can result in the leakage of corrosive process fluids and cause injury to personnel and/or damage to plant facilities. It is also possible that the diaphragm itself can be damaged and that material from the broken diaphragm and the fill fluid can contaminate the user's process fluids.

Be very careful with highly corrosive process fluids such as hydrochloric acid, sulfuric acid, hydrogen sulfide, sodium hypochlorite, and high-temperature steam (150°C [302°F] or above). Contact Yokogawa for detailed information of the wetted parts material.

*6: Forged version of the material may be used.

The "# marks indicate the construction materials conform to NACE material recommendations per MR01-75. For the use of 316 SST material, there may be certain limitations for pressure and temperature. Please refer to NACE standards for details.

II. Diaphragm seal section (Extended type)

● Process connection size: 4-inch (100 mm) / 3-inch (80 mm)

EJX118A-□□□□-□□□□-E 4 3 □□□□-□□□□

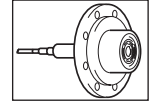

F09E.EPS

Model	Suffix codes	Description
EJX118A	-□□□□-□□□□	Transmitter body section (I)
Process connection style	-E	Extended type
Flange rating	J1 JIS 10K J2 JIS 20K A1 ANSI class 150 A2 ANSI class 300 P1 JPI class 150 P2 JPI class 300 D2 DIN PN10/16 D4 DIN PN25/40	
Process connection size (Process flange size)	4 4-inch (100 mm) 3 3-inch (80 mm)	
Flange material	☆ A JIS S25C ☆ B 304 SST *5 ☆ C 316 SST *5	
Gasket contact surface*1	1 Serration (for ANSI flange only) 2 Flat (no serration)	
Wetted parts material*4	SE [Diaphragm] [Pipe] [Others] 316L SST# 316 SST # 316 SST #	
Flushing connection ring	0 None	
Extension	2 Length (X ₂) = 50 mm 4 Length (X ₂) = 100 mm 6 Length (X ₂) = 150 mm	
Fill fluid	☆ -A For general use (silicone oil) [Process temperature] -10 to 250°C [Ambient temperature] -10 to 60°C ☆ -B For general use (silicone oil) -30 to 180°C -15 to 60°C ☆ -C For high temperature use (silicone oil) 10 to 310°C 10 to 60°C ☆ -D For oil-prohibited use (fluorinated oil)*2 -20 to 120°C -10 to 60°C ☆ -E For low temperature use (ethylene glycol) -50 to 100°C -40 to 60°C	
Capillary connection	B Back of diaphragm seal unit	
—	2 Always 2	
Capillary length*3	1 1 m 2 2 m 3 3 m 4 4 m 5 5 m 6 6 m 7 7 m 8 8 m 9 9 m A 10 m	
Option codes	/□ Optional specification	

T11E.EPS

The "☆" marks indicate the most typical selection for each specification. Example: EJX118A-DMSCG-912EN-EA14B1SE02-BB25/□

*1: See table 3 'Gasket contact surface' on page 5.

*2: Even in case where fill fluid code **D** (fluorinated oil) is selected, if decrease cleansing treatment or both degrease cleansing and dehydrating treatment for the wetted parts is required, specify option code **K1** or **K5**.

*3: The specified capillary length includes the extension length (X₂) and the flange thickness (t).

*4: ⚠ Users must consider the characteristics of selected wetted parts material and the influence of process fluids. The use of inappropriate materials can result in the leakage of corrosive process fluids and cause injury to personnel and/or damage to plant facilities. It is also possible that the diaphragm itself can be damaged and that material from the broken diaphragm and the fill fluid can contaminate the user's process fluids.

Be very careful with highly corrosive process fluids such as hydrochloric acid, sulfuric acid, hydrogen sulfide, sodium hypochlorite, and high-temperature steam (150°C [302°F] or above). Contact Yokogawa for detailed information of the wetted parts material.

*5: Forged version of the material may be used.

The #marks indicate the construction materials conform to NACE material recommendations per MR01-75. For the use of 316 SST material, there may be certain limitations for pressure and temperature. Please refer to NACE standards for details.

II. Diaphragm seal section (Combination type)

- Process connection size: High pressure side ; 4-inch (100 mm) ●●● Extended type
- Low pressure side ; 3-inch (80 mm) ●●● Flush type

EJX118A-□□□□□-□□□□□-Y □ W □□□□□-□□□□□

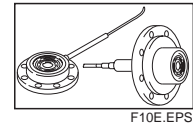

F10E.EPS

Model	Suffix codes	Description
EJX118A	-□□□□□-□□□□□	Transmitter body section (I)
Process connection style	-Y	Combination type (Extended and Flush)
Flange rating	J1 JIS 10K J2 JIS 20K A1 ANSI class 150 A2 ANSI class 300 P1 JPI class 150 P2 JPI class 300 D2 DIN PN10/16 D4 DIN PN25/40	
Process connection size (Process flange size)	W	High pressure side 4-inch (100 mm) Low pressure side 3-inch (80 mm)
Flange material	A JIS S25C ☆ B 304 SST *5 C 316 SST *5	
Gasket contact surface *1	1 Serration (for ANSI flange only) 2 Flat (no serration)	
Wetted parts material *4	SY	[Diaphragm] [Pipe] [Others] High pressure side: 316L SST # 316 SST # 316 SST # Low pressure side: 316L SST # — 316L SST #
Flushing connection ring	0	None
Extension	1 Length (X ₂) = 50 mm 3 Length (X ₂) = 100 mm 5 Length (X ₂) = 150 mm	
Fill fluid	☆ -A For general use (silicone oil) [Process temperature] -10 to 250°C [Ambient temperature] -10 to 60°C ☆ -B For general use (silicone oil) -30 to 180°C -15 to 60°C -C For high temperature use (silicone oil) 10 to 310°C 10 to 60°C -D For oil-prohibited use (fluorinated oil)*2 -20 to 120°C -10 to 60°C -E For low temperature use (ethylene glycol) -50 to 100°C -40 to 60°C	
Capillary connection	C	High pressure side: Back of diaphragm seal unit Low pressure side: Side of diaphragm seal unit
—	2	Always 2
Capillary length*3	1 1 m 2 2 m 3 3 m 4 4 m 5 5 m 6 6 m 7 7 m 8 8 m 9 9 m A 10 m	
Option codes		<input type="checkbox"/> Optional specification

T12E.EPS

The “☆” marks indicate the most typical selection for each specification. Example: EJX118A-DMSCG-912EN-YA1WB1SY01-BC25/□

- *1: See table 3 'Gasket contact surface' on page 5.
 - *2: Even in case where fill fluid code **D** (fluorinated oil) is selected, if degrease cleansing treatment or both degrease cleansing and dehydrating treatment for the wetted parts is required, specify option code **K1** or **K5**.
 - *3: The specified capillary length of high pressure side (extended side) includes the extension length (X₂) and the flange thickness (t).
 - *4: ⚠ Users must consider the characteristics of selected wetted parts material and the influence of process fluids. The use of inappropriate materials can result in the leakage of corrosive process fluids and cause injury to personnel and/or damage to plant facilities. It is also possible that the diaphragm itself can be damaged and that material from the broken diaphragm and the fill fluid can contaminate the user's process fluids.
Be very careful with highly corrosive process fluids such as hydrochloric acid, sulfuric acid, hydrogen sulfide, sodium hypochlorite, and high-temperature steam (150°C [302°F] or above). Contact Yokogawa for detailed information of the wetted parts material.
 - *5: Forged version of the material may be used.
- The # marks indicate the construction materials conform to NACE material recommendations per MR01-75. For the use of 316 SST material, there may be certain limitations for pressure and temperature. Please refer to NACE standards for details.

OPTIONAL SPECIFICATIONS (For Explosion Protected type) “◇”

Item	Description	Code
Factory Mutual (FM)	FM Explosionproof Approval *1 Applicable Standard: FM3600, FM3615, FM3810, ANSI/NEMA 250 Explosionproof for Class I, Division 1, Groups B, C and D, Dust-ignitionproof for Class II/III, Division 1, Groups E, F and G, in Hazardous locations, indoors and outdoors (NEMA 4X) Temperature class: T6, Amb. Temp.: -40 to 60°C (-40 to 140°F)	FF1
	FM Intrinsically safe Approval *1*2 Applicable Standard: FM3600, FM3610, FM3611, FM3810 Intrinsically Safe for Class I, Division 1, Groups A, B, C & D, Class II, Division 1, Groups E, F & G and Class III, Division 1, Class I, Zone 0, in Hazardous Locations, AEx ia IIC Nonincendive for Class I, Division 2, Groups A, B, C & D, Class II, Division. 2, Groups F & G, and Class III, Division 1, Class I, Zone 2, Group IIC, in Hazardous Locations Enclosure: "NEMA 4X", Temp. Class: T4, Amb. Temp.: -60 to 60°C (-75 to 140°F) Intrinsically Safe Apparatus Parameters [Groups A, B, C, D, E, F and G] Vmax=30 V, Imax=200 mA, Pmax=1 W, Ci=6 nF, Li=0 μH [Groups C, D, E, F and G] Vmax=30 V, Imax=225 mA, Pmax=1 W, Ci=6 nF, Li=0 μH	FS1
	Combined FF1 and FS1 *1*2	FU1
CENELEC ATEX	CENELEC ATEX (KEMA) Flameproof Approval *1 Applicable Standard: EN 60079-0, EN 60079-1, EN 61241-0, EN 61241-1 Certificate: KEMA 07ATEX0109 II 2G, 2D Exd IIC T4, T5, T6 Ex tD A21 IP6X T85, T100, T120 Degree of protection : IP66 and IP67 Amb. Temp. (Tamb) for gas-proof : T4 ; -50 to 75°C (-58 to 167°F), T5; -50 to 80°C (-58 to 176°F), T6; -50 to 75°C (-58 to 167°F) Max. process Temp.(Tp): T4; 120°C (248°F), T5; 100°C (212°F), T6; 85°C (185°F) Max. surface Temp. for dust-proof : T85°C (Tamb: -40 to 40°C, Tp:85°C), T100°C (Tamb: -40 to 60°C, Tp:100°C), T120°C (Tamb: -40 to 80°C, Tp:120°C)	KF21
	CENELEC ATEX (KEMA) Intrinsically safe Approval *1*2 Applicable Standard: EN 50014, EN 50020, EN 50284, EN 50281-1-1 Certificate: KEMA 03ATEX1544X II 1G, 1D EEx ia IIC T4 Degree of protection : IP66 and IP67 Amb. Temp.(Tamb) for gas-proof: -50 to 60°C (-58 to 140°F) Maximum Process Temp.(Tp) for gas-proof :120°C Electrical data : Ui=30 V, li=200 mA, Pi=0.9 W, Ci=10 nF, Li=0 mH Max. surface Temp. for dust-proof : T85°C (Tamb: -40 to 60°C, Tp:80°C), T100°C (Tamb: -40 to 60°C, Tp:100°C), T120°C (Tamb: -40 to 60°C, Tp:120°C)	KS2
	Combined KF21, KS2 and Type n *1*2 Type n Applicable standard: EN60079-15 Referential standard: IEC60079-0, IEC60079-11 II 3G Ex nL IIC T4, Amb. Temp.: -50 to 60°C (-50 to 140°F) Ui=30 V DC, Ci=10 nF, Li=0 mH	KU21

T05E.EPS

*1: Applicable for Electrical connection code **2, 4, 7, 9, C** and **D**.

*2: Not applicable for option code **/AL**.

Item	Description	Code
Canadian Standards Association (CSA)	<p>CSA Explosionproof Approval *1 Certificate: 2014354 Applicable Standard: C22.2 No.0, C22.2 No.0.4, C22.2 No.0.5, C22.2 No.25, C22.2 No.30, C22.2 No.94, C22.2 No.60079-0, C22.2 No.60079-1, C22.2 No.61010-1-01 Explosion-proof for Class I, Groups B, C and D. Dustrignition-proof for Class II/III, Groups E, F and G. When installed in Division 2, "SEAL NOT REQUIRED" Enclosure: TYPE 4X, Temp. Code: T6...T4 Ex d IIC T6...T4 Enclosure: IP66 and IP67 Max.Process Temp.: T4;120°C(248°F), T5;100°C(212 °F), T6; 85°C(185°F) Amb.Temp.: -50 to 75°C(-58 to 167°F) for T4, -50 to 80°C(-58 to 176°F) for T5, -50 to 75°C(-58 to 167°F) for T6</p> <p>Process Sealing Certification Dual Seal Certified by CSA to the requirement of ANSI/ISA 12.27.01 No additional sealing required Primary seal failure annunciation: at the zero adjustment screw</p>	CF1
	<p>CSA Intrinsically safe Approval *1*2 Certificate: 1606623 [For CSA C22.2] Applicable Standard: C22.2 No.0, C22.2 No.0.4, C22.2 No.25, C22.2 No.94, C22.2 No.154, C22.2 No.213, C22.2 No.1010.1 Intrinsically Safe for Class I, Division 1, Groups A, B, C & D, Class II, Division 1, Groups E, F & G, Class III, Division 1, Nonincendive for Class I, Division 2, Groups A, B, C & D, Class II, Division 2, Groups E, F & G, Class III, Division 1 Enclosure: Type 4X, Temp. Code: T4 Amb. Temp.: -50 to 60°C(-58 to 140°F) Electrical Parameters: [Intrinsically Safe] Vmax=30V, Imax=200mA, Pmax=0.9W, Ci=10nF, Li=0 [Nonincendive] Vmax=30V, Ci=10nF, Li=0</p> <p>[For CSA E60079] Applicable Standard: CAN/CSA E60079-0, CAN/CSA E60079-11, CAN/CSA E60079-15, IEC 60529:2001-02 Ex ia IIC T4, Ex nL IIC T4 Enclosure: IP66 and IP67 Amb. Temp.: -50 to 60°C(-58 to 140°F), Max. Process Temp.: 120°C(248°F) Electrical Parameters: [Ex ia] Ui=30V, li=200mA, Pi=0.9W, Ci=10nF, Li=0 [Ex nL] Ui=30V, Ci=10nF, Li=0</p> <p>Process Sealing Certification Dual Seal Certified by CSA to the requirement of ANSI/ISA 12.27.01 No additional sealing required Primary seal failure annunciation: at the zero adjustment screw</p>	CS1
	Combined CF1 and CS1 *1*2	CU1
IECEX Scheme *3	<p>IECEX Flameproof Approval *1 Applicable Standard: IEC 60079-0:2004, IEC60079-1:2003 Certificate: IECEX CSA 07.0008 Flameproof for Zone 1, Ex d IIC T6...T4 Enclosure: IP66 and IP67 Max.Process Temp.: T4;120°C(248°F), T5;100°C(212°F), T6; 85°C(185°F) Amb.Temp.: -50 to 75°C(-58 to 167°F) for T4, -50 to 80°C(-58 to 176°F) for T5, -50 to 75°C(-58 to 167°F) for T6</p>	SF2
	<p>IECEX Intrinsically safe, type n and Flameproof Approval *1*2 Intrinsically safe and type n Applicable Standard: IEC 60079-0:2000, IEC 60079-11:1999, IEC 60079-15:2001 Certificate: IECEX CSA 05.0005 Ex ia IIC T4, Ex nL IIC T4 Enclosure: IP66 and IP67 Amb. Temp.: -50 to 60°C(-58 to 140°F), Max. Process Temp.: 120°C(248°F) Electrical Parameters: [Ex ia] Ui=30V, li=200mA, Pi=0.9W, Ci=10nF, Li=0 [Ex nL] Ui=30V, Ci=10nF, Li=0</p> <p>Flameproof Applicable Standard: IEC 60079-0:2004, IEC60079-1:2003 Certificate: IECEX CSA 07.0008 Flameproof for Zone 1, Ex d IIC T6...T4 Enclosure: IP66 and IP67 Max.Process Temp.: T4;120°C(248°F), T5;100°C(212°F), T6; 85°C(185°F) Amb.Temp.: -50 to 75°C(-58 to 167°F) for T4, -50 to 80°C(-58 to 176°F) for T5, -50 to 75°C(-58 to 167°F) for T6</p>	SU2
Combination of approval	Combination of KU21, FU1 and CU1 *1*2	V1U

*1: Applicable for Electrical connection code **2, 4, 7, 9, C** and **D**.
 *2: Not applicable for option code **/AL**.
 *3: Applicable only for Australia, New Zealand, Singapore and India.

T05Eb.EPS

OPTIONAL SPECIFICATIONS

Item		Description	Code
Painting	Color change	Amplifier cover only* ⁹	P□
		Amplifier cover and terminal cover, Munsell 7.5 R4/14	PR
	Coating change	Anti-corrosion coating* ¹⁹	X2
316 SST exterior parts		316 SST name plate, tag plate and zero-adjustment screw* ¹²	HC
Lightning protector		Transmitter power supply voltage: 10.5 to 32 V DC (10.5 to 30 V DC for intrinsically safe type.) Allowable current: Max. 6000 A (1×40 μs), Repeating 1000 A (1×40 μs) 100 times Applicable Standards: IEC 61000-4-4, IEC 61000-4-5	A
Status output * ¹⁰		Transistor output (sink type) Contact rating: 10.5 to 30 V DC, 120 mA DC (max) Low level: 0 to 2 V DC	AL
Oil-prohibited use		Degrease cleansing treatment	K1
Oil-prohibited use with dehydrating treatment		Degrease cleansing treatment and dehydrating treatment	K5
Calibration units * ³	P calibration (psi unit)		(See table for Span and Range Limits.)
	bar calibration (bar unit)		
	M calibration (kgf/cm ² unit)		
Teflon film * ² * ¹¹		Diaphragm protection from sticky process fluid by FEP Teflon film attached with fluorinated oil. Operation range: 20 to 150°C, 0 to 2 MPa (Not applicable for vacuum service).	TF1
Operating temperature correction * ⁵		Adjusting range : 80°C to Maximum temperature of specified fill fluid	R
Capillary without PVC sheaths		When ambient temperature exceeds 100°C, or use of PVC is prohibited	V
Output limits and failure operation * ⁴	Failure alarm down-scale : Output status at CPU failure and hardware error is -5%, 3.2 mA DC or less.		C1
	NAMUR NE43 Compliant Output signal limits : 3.8 mA to 20.5 mA	Failure alarm down-scale : Output status at CPU failure and hardware error is -5%, 3.2 mA DC or less.	C2
		Failure alarm up-scale : Output status at CPU failure and hardware error is 110%, 21.6 mA or more.	C3
Gold-plated diaphragm * ⁶		Inside of isolating diaphragms (fill fluid side) are gold plated, effective for hydrogen permeation.	A1
Wired tag plate		304SST tag plate wired onto transmitter (316 SST when /HC is specified)	N4
Data configuration at factory * ⁷	Data configuration for HART communication type	Software damping, Descriptor, Message	CA
	Data configuration for BRAIN communication type	Software damping	CB
Advanced diagnostics * ¹³		Multi-sensing process monitoring • Impulse line blockage detection * ¹⁴	DG6
Material certificate	Process flange, Block	For Flush type	M2W
	Process flange, Block, Ring * ⁸		M5W
	Process flange, Block, Pipe, Base	For Extended type	M2E
	High Pressure side: Process flange, Block Low Pressure side: Process flange, Block	For Combination type	M2Y

T14E.EPS

- *1: Not applicable with color change option.
- *2: Applicable for flush type (process connection style code **W**.)
- *3: The unit of MWP (Max. working pressure) on the name plate of a housing is the same unit as specified by option code **D1**, **D3**, and **D4**.
- *4: Applicable for output signal code **D** and **E**. The hardware error indicates faulty amplifier or capsule.
- *5: Specify the process operating temperature for zero correction. Example: Zero correction by process temperature 90°C.
- *6: Applicable for wetted parts material code **SW**, **SE**, **SY**, and **HW**.
- *7: Also see 'Ordering Information.'
- *8: Applicable for flushing connection ring code **1**, **2**, **3**, and **4**.
- *9: Not applicable for amplifier housing code **2**.
- *10: Check terminals cannot be used when this option is specified. Not applicable for output signal code **F**.
- *11: Applicable for flushing connection ring code **0**.
- *12: 316 or 316L SST. The specification is included in amplifier code **2**.
- *13: Applicable only for output signal code **-E**.
- *14: The change of pressure fluctuation is monitored and then detects the impulse line blockage. See TI 01C25A31-01E for detailed technical information required for using this function.

Item	Description	Code	
Pressure test/Leak test Certificate *4*5	(Flange rating)	(Test pressure)	
	JIS 10K	2 MPa (290 psi)	T51
	JIS 20K	5 MPa (720 psi)	T54
	JIS 40K *1	10 MPa (1450 psi)	T57
	ANSI/JPI Class 150	3 MPa (430 psi)	T52
	ANSI/JPI Class 300 *1	8 MPa (1160 psi)	T56
	ANSI/JPI Class 300 *2	7 MPa (1000 psi)	T55
	ANSI/JPI Class 600 *1	16 MPa (2300 psi)	T58

T14-2E.EPS

- *1: Applicable for flush type (process connection style code **W**.)
- *2: Applicable for extended type and Combination type (process connection style code **E** and **Y**.)
- *3: Pure nitrogen gas is used for oil-prohibited use (option code **K1** and **K5**.)
- *4: The unit on the certificate is always MPa regardless of selection of option code D1, D3, or D4.
- *5: A flushing connection ring will not be applied when conducting the pressure test or leak test.

DIMENSIONS

Transmitter body section

Unit: mm (Approx.: inch)

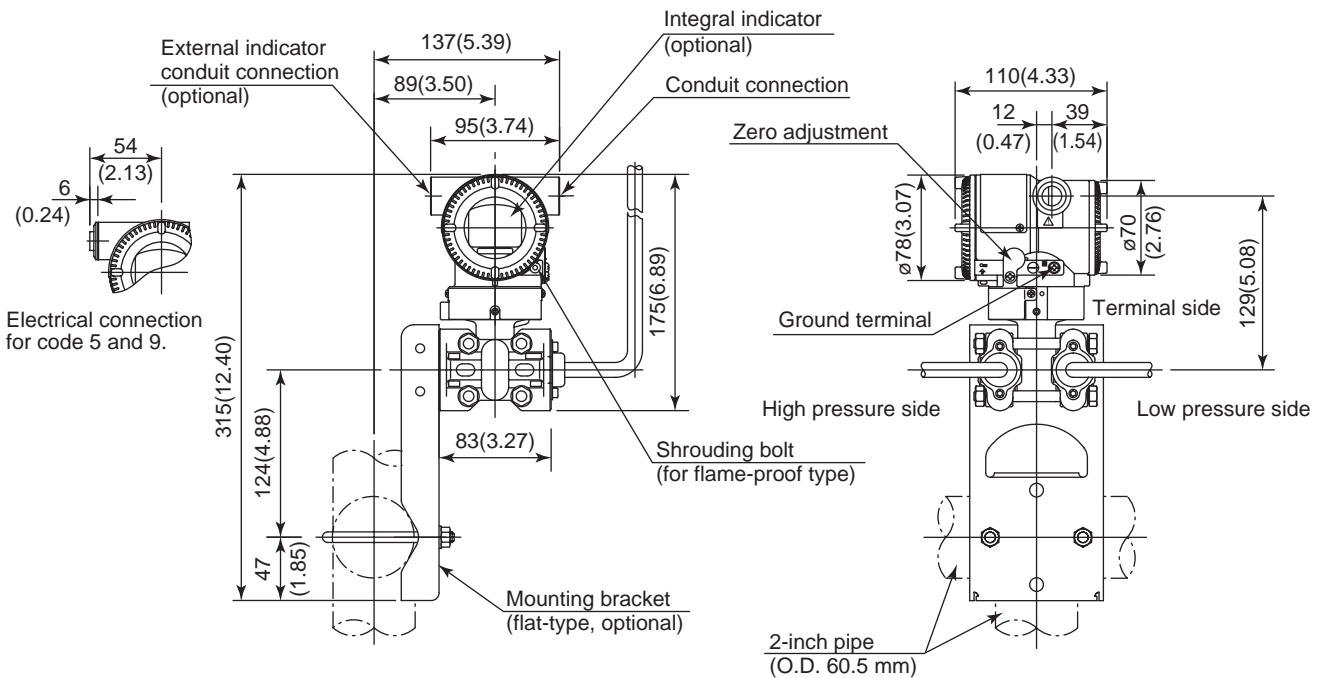

F11E.EPS

<Diaphragm seal section>

● Flush type

Unit: mm (Approx.: inch)

- No ring (Flushing connection ring code 0)

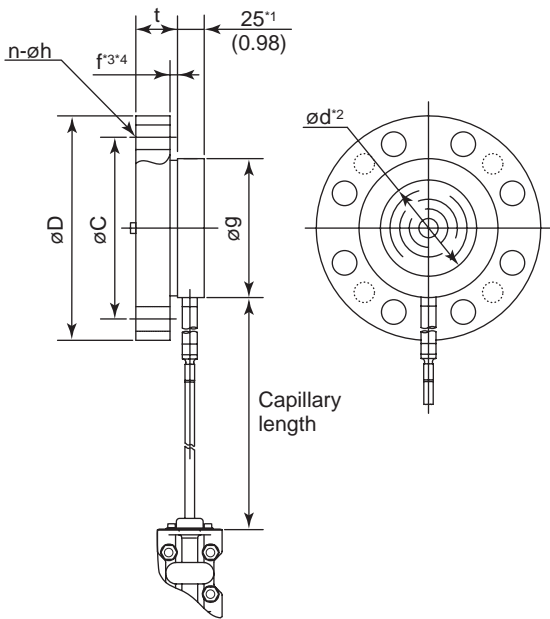

- With ring (Flushing connection ring code 1, 2, 3, and 4)

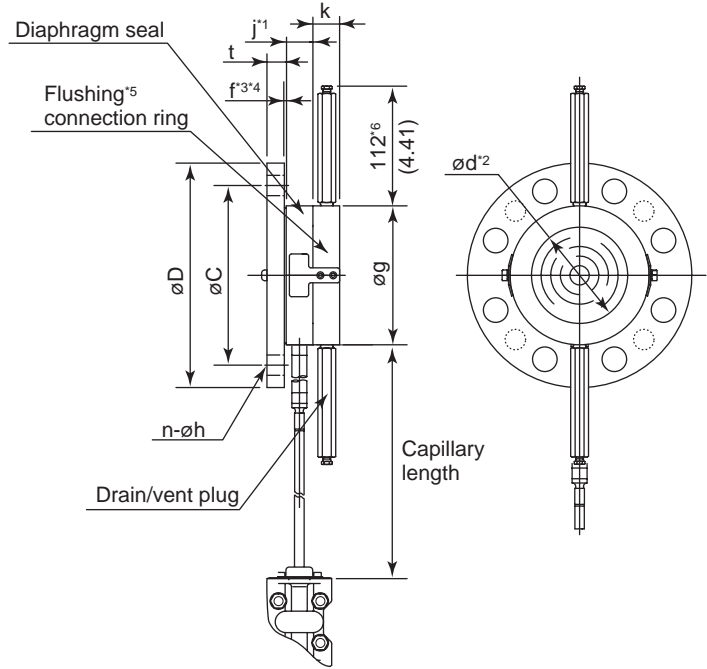

● Extended type

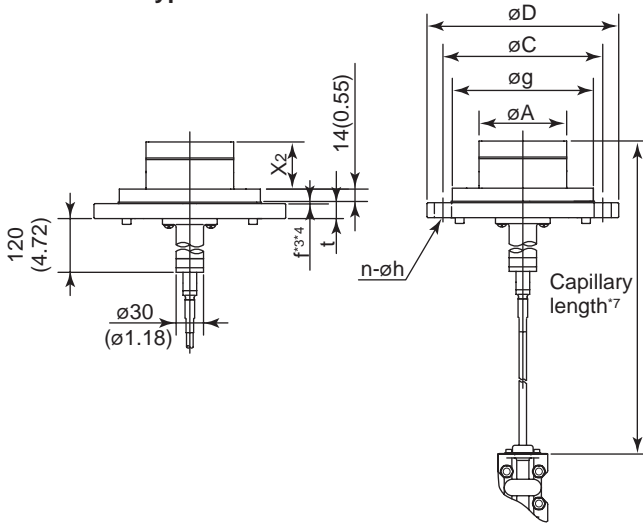

*1: When wetted parts material code **UW** (titanium), value is 34 (1.34)

*2: Indicates inside diameter of gasket contact surface

*3: In case where process flange material is JIS S25C, value of f is 0.

*4: In case where process flange material is JIS SUS304 in ANSI/JPI flange, value of f is included in t.

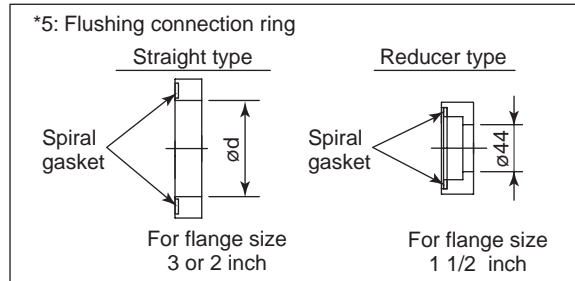

*5: Flushing connection ring

*6: When option code **K1** or **K5** is selected, add 11 mm (0.28 inch.)

*7: The specified capillary length includes the extension length (X₂) and the flange thickness (t).

F12E.EPS

● Extension length (X₂)

Extension code	X ₂
2	50(1.97)
4	100(3.94)
6	150(5.91)

T15E.EPS

● Combination type

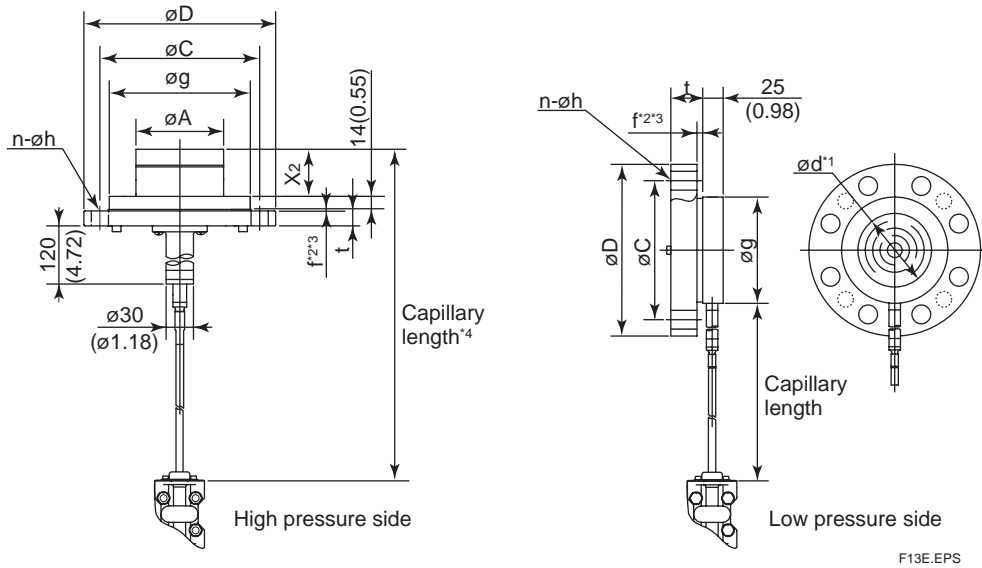

F13E.EPS

*1: Indicates inside diameter of gasket contact surface.

*2: In case where process flange material is JIS S25C, value of f is 0.

*3: In case where process flange material is JIS SUS304 in ANSI/JPI flange, value of f is included in t.

*4: The specified capillary length includes the extension length (X_2) and the flange thickness (t).

● Extension length (X2)

Extension code	X2
1	50(1.97)
3	100(3.94)
5	150(5.91)

T16E.EPS

Unit: mm (Approx.: inch)

Process flange size: 4 inch (100 mm)

Code	Flange rating	øD	øC	øg	ød	t	f ^{3*4}	Bolt holes		j	k	øA
								No.(n)	Dia.(øh)			
J1	JIS 10K	210 (8.27)	175 (6.89)	155 (6.10)	—	18 (0.71)	0	8	19 (0.75)	—	—	96±0.5 (3.78±0.02)
J2	JIS 20K	225 (8.86)	185 (7.28)	155 (6.10)	—	24 (0.94)	0	8	23 (0.91)	—	—	96±0.5 (3.78±0.02)
A1	ANSI class 150	228.6 (9.00)	190.5 (7.50)	155 (6.10)	—	23.9 (0.94)	1.6 (0.06)	8	19.1 (0.75)	—	—	96±0.5 (3.78±0.02)
A2	ANSI class 300	254 (10.00)	200.2 (7.88)	155 (6.10)	—	31.8 (1.25)	1.6 (0.06)	8	22.4 (0.88)	—	—	96±0.5 (3.78±0.02)
P1	JPI class 150	229 (9.02)	190.5 (7.50)	155 (6.10)	—	24 (0.94)	1.6 (0.06)	8	19 (0.75)	—	—	96±0.5 (3.78±0.02)
P2	JPI class 300	254 (10.0)	200.2 (7.88)	155 (6.10)	—	32 (1.26)	1.6 (0.06)	8	22 (0.87)	—	—	96±0.5 (3.78±0.02)
D2	DIN PN10/16	220 (8.66)	180 (7.09)	155 (6.10)	—	20 (0.79)	0	8	18 (0.71)	—	—	96±0.5 (3.78±0.02)
D4	DIN PN25/40	235 (9.25)	190 (7.48)	155 (6.10)	—	24 (0.94)	0	8	22 (0.87)	—	—	96±0.5 (3.78±0.02)

Process flange size: 3 inch (80 mm)

Code	Flange rating	øD	øC	øg	ød ²	t	f ^{3*4}	Bolt holes		j ¹	k	øA
								No.(n)	Dia.(øh)			
J1	JIS 10K	185 (7.28)	150 (5.91)	130 (5.12)	90 (3.54)	18 (0.71)	0	8	19 (0.75)	25 (0.98)	27 (1.06)	71±0.5 (2.8±0.02)
J2	JIS 20K	200 (7.87)	160 (6.30)	130 (5.12)	90 (3.54)	22 (0.87)	0	8	23 (0.91)	25 (0.98)	27 (1.06)	71±0.5 (2.8±0.02)
J4	JIS 40K	210 (8.27)	170 (6.69)	130 (5.12)	90 (3.54)	32 (1.26)	0	8	23 (0.91)	25 (0.98)	27 (1.06)	—
A1	ANSI class 150	190.5 (7.50)	152.4 (6.00)	130 (5.12)	90 (3.54)	23.9 (0.94)	1.6 (0.06)	4	19.1 (0.75)	25 (0.98)	27 (1.06)	71±0.5 (2.8±0.02)
A2	ANSI class 300	209.6 (8.25)	168.1 (6.62)	130 (5.12)	90 (3.54)	28.5 (1.12)	1.6 (0.06)	8	22.4 (0.88)	25 (0.98)	27 (1.06)	71±0.5 (2.8±0.02)
A4	ANSI class 600	209.6 (8.25)	168.1 (6.62)	130 (5.12)	90 (3.54)	38.2 (1.50)	6.4 (0.25)	8	22.4 (0.88)	25 (0.98)	27 (1.06)	—
P1	JPI class 150	190 (7.48)	152.4 (6.00)	130 (5.12)	90 (3.54)	24 (0.94)	1.6 (0.06)	4	19 (0.75)	25 (0.98)	27 (1.06)	71±0.5 (2.8±0.02)
P2	JPI class 300	210 (8.27)	168.1 (6.61)	130 (5.12)	90 (3.54)	28.5 (1.12)	1.6 (0.06)	8	22 (0.87)	25 (0.98)	27 (1.06)	71±0.5 (2.8±0.02)
P4	JPI class 600	210 (8.27)	168.1 (6.61)	130 (5.12)	90 (3.54)	38.4 (1.51)	6.4 (0.25)	8	22 (0.87)	25 (0.98)	27 (1.06)	—
D2	DIN PN10/16	200 (7.87)	160 (6.30)	130 (5.12)	90 (3.54)	20 (0.79)	0	8	18 (0.71)	25 (0.98)	27 (1.06)	71±0.5 (2.8±0.02)
D4	DIN PN25/40	200 (7.87)	160 (6.30)	130 (5.12)	90 (3.54)	24 (0.94)	0	8	18 (0.71)	25 (0.98)	27 (1.06)	71±0.5 (2.8±0.02)
D5	DIN PN64	215 (8.46)	170 (6.69)	130 (5.12)	90 (3.54)	28 (1.10)	0	8	22 (0.87)	25 (0.98)	27 (1.06)	—

Process flange size: 2 inch (50 mm)

Code	Flange rating	øD	øC	øg	ød ²	t	f ^{3*4}	Bolt holes		j	k
								No.(n)	Dia.(øh)		
J1	JIS 10K	155 (6.10)	120 (4.72)	100 (3.94)	61 (2.40)	16 (0.63)	0	4	19 (0.75)	25 (0.98)	27 (1.06)
J2	JIS 20K	155 (6.10)	120 (4.72)	100 (3.94)	61 (2.40)	18 (0.71)	0	8	19 (0.75)	25 (0.98)	27 (1.06)
J4	JIS 40K	165 (6.50)	130 (5.12)	100 (3.94)	61 (2.40)	26 (1.02)	0	8	19 (0.75)	25 (0.98)	27 (1.06)
A1	ANSI class 150	152.4 (6.00)	120.7 (4.75)	100 (3.94)	61 (2.40)	19.1 (0.75)	1.6 (0.06)	4	19.1 (0.75)	25 (0.98)	27 (1.06)
A2	ANSI class 300	165.1 (6.50)	127.0 (5.00)	100 (3.94)	61 (2.40)	22.4 (0.88)	1.6 (0.06)	8	19.1 (0.75)	25 (0.98)	27 (1.06)
A4	ANSI class 600	165.1 (6.50)	127.0 (5.00)	100 (3.94)	61 (2.40)	31.8 (1.25)	6.4 (0.25)	8	19.1 (0.75)	25 (0.98)	27 (1.06)
P1	JPI class 150	152 (5.98)	120.6 (4.75)	100 (3.94)	61 (2.40)	19.5 (0.77)	1.6 (0.06)	4	19 (0.75)	25 (0.98)	27 (1.06)
P2	JPI class 300	165 (6.50)	127.0 (5.00)	100 (3.94)	61 (2.40)	22.4 (0.88)	1.6 (0.06)	8	19 (0.75)	25 (0.98)	27 (1.06)
P4	JPI class 600	165 (6.50)	127.0 (5.00)	100 (3.94)	61 (2.40)	31.9 (1.26)	6.4 (0.25)	8	19 (0.75)	25 (0.98)	27 (1.06)
D2	DIN PN10/16	165 (6.50)	125 (4.92)	100 (3.94)	61 (2.40)	18 (0.71)	0	4	18 (0.71)	25 (0.98)	27 (1.06)
D4	DIN PN25/40	165 (6.50)	125 (4.92)	100 (3.94)	61 (2.40)	20 (0.79)	0	4	18 (0.71)	25 (0.98)	27 (1.06)
D5	DIN PN64	180 (7.09)	135 (5.31)	100 (3.94)	61 (2.40)	26 (1.02)	0	4	22 (0.87)	25 (0.98)	27 (1.06)

Process flange size: 1 1/2 inch (40 mm)

Code	Flange rating	øD	øC	øg	ød ²	t	f ^{3*4}	Bolt holes		j	k
								No.(n)	Dia.(øh)		
J1	JIS 10K	140 (5.51)	105 (4.13)	86 (3.39)	44 (1.73)	16 (0.63)	0	4	19 (0.75)	27 (1.06)	30 (1.18)
J2	JIS 20K	140 (5.51)	105 (4.13)	86 (3.39)	44 (1.73)	18 (0.71)	0	4	19 (0.75)	27 (1.06)	30 (1.18)
J4	JIS 40K	160 (6.30)	120 (4.72)	86 (3.39)	44 (1.73)	24 (0.94)	0	4	23 (0.91)	27 (1.06)	30 (1.18)
A1	ANSI class 150	127 (5.00)	98.6 (3.88)	86 (3.39)	44 (1.73)	17.5 (0.69)	1.6 (0.06)	4	15.9 (0.63)	27 (1.06)	30 (1.18)
A2	ANSI class 300	155.4 (6.12)	114.3 (4.50)	86 (3.39)	44 (1.73)	20.6 (0.81)	1.6 (0.06)	4	22.4 (0.88)	27 (1.06)	30 (1.18)
A4	ANSI class 600	155.4 (6.12)	114.3 (4.50)	86 (3.39)	44 (1.73)	28.8 (1.13)	6.4 (0.25)	4	22.4 (0.88)	27 (1.06)	30 (1.18)
P1	JPI class 150	127 (5.00)	98.6 (3.88)	86 (3.39)	44 (1.73)	17.6 (0.69)	1.6 (0.06)	4	16 (0.63)	27 (1.06)	30 (1.18)
P2	JPI class 300	155 (6.10)	114.3 (4.50)	86 (3.39)	44 (1.73)	20.6 (0.81)	1.6 (0.06)	4	22 (0.87)	27 (1.06)	30 (1.18)
P4	JPI class 600	155 (6.10)	114.3 (4.50)	86 (3.39)	44 (1.73)	28.9 (1.14)	6.4 (0.25)	4	22 (0.87)	27 (1.06)	30 (1.18)

- *1: When wetted parts material code **UW** (titanium) is selected, value is 34 (1.34).
- *2: Indicates inside diameter of gasket contact surface.
- *3: In case where process flange material is JIS S25C, value of f is 0.
- *4: In case where process flange material is JIS SUS304 in ANSI/JPI flange, value of f is included in t.

T17E.EPS

● Terminal Configuration

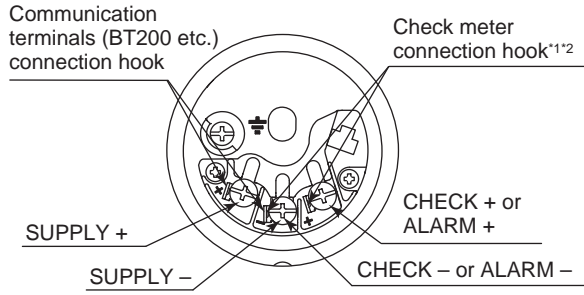

● Terminal Wiring

SUPPLY	+ -	Power supply and output terminal
CHECK or ALARM	+ -	External indicator (ammeter) terminal ^{*1,2} or Status contact output terminal ² (when /AL is specified)
		Ground terminal

*1: When using an external indicator or check meter, the internal resistance must be 10 Ω or less. A check meter or indicator cannot be connected when /AL option is specified.

*2: Not available for fieldbus communication type.

F14E.EPS

● Wiring Example for Analog Output and Status Output

Connection	Description
Analog output	<p>EJX Electrical Terminal</p> <p>Distributor</p> <p>24V DC</p> <p>250Ω</p>
Analog and Status output (when /AL is specified)	<p>EJX Electrical terminal</p> <p>Shielded Cable</p> <p>SUPPLY +</p> <p>ALARM +</p> <p>External Power supply 30V DC, 120mA max</p> <p>Distributor</p> <p>24V DC</p> <p>250Ω</p> <p>Magnetic valve</p> <p>AC power supply</p> <p>Use two-wire separately shielded cables.</p> <p>If shield cable is not used, communication is not possible.</p>

F15E.EPS

< Ordering Information >

Specify the following when ordering

1. Model, suffix codes, and option codes
2. Calibration range and units:
 - 1) Calibration range can be specified with range value specifications up to 5 digits (excluding any decimal point) for low or high range limits within the range of -32000 to 32000. When reverse range is designated, specify LRV as greater than URV. When square root output mode is specified, LRV must be "0(zero)".
 - 2) Specify only one unit from the table, 'Factory setting.'
3. Select linear or square root for output mode and display mode.

Note: If not specified, the instrument is shipped set for linear mode.
4. Display scale and units (for transmitters equipped with the integral indicator only)

Specify either 0 to 100 % or 'Range and Unit' for engineering units scale:
Scale range can be specified with range limit specifications up to 5 digits (excluding any decimal point) for low or high range limits within the range of -32000 to 32000. Unit display consists of 6-digit, therefore, if the specified scaling unit excluding '/' is longer than 6-characters, the first 6 characters will be displayed on the unit display.
5. Tag Number (if required).

For BRAIN communication type, specify upto 16 letters. The specified letters will be written in the amplifier memory and engraved on the tag plate.
For HART communication type, specify software tag (upto 8 letters) to be written on the amplifier memory and Tag number(upto 16 letters) to be engraved on the tag plate seperately.
6. Other factory configurations (if required)

Specifying option code /**CA** or /**CB** will allow further configuration at factory. Following are configurable items and setting range.

[/CA : For HART communication type]

 - 1) Descriptor(upto 16 characters)
 - 2) Message (upto 30 characters)
 - 3) Software damping (0.00 to 100.00 sec)

[/CB : For BRAIN communication type]

 - 1) Software damping (0.00 to 100.00 sec)
7. Process fluid temperature for zero compensation (if required)

< Factory Setting >

Tag Number	As specified in order
Software damping *1	'2.00 sec' or as specified in order
Output mode	'Linear' unless otherwise specified in order
Calibration range lower range value	As specified in order
Calibration range upper range value	As specified in order
Calibration range units	Selected from mmH ₂ O, mmH ₂ O(68°F), mmAq ^{*2} , mmWG ^{*2} , mmHg, Pa, hPa ^{*2} , kPa, MPa, mbar, bar, gf/cm ² , kgf/cm ² , inH ₂ O, inH ₂ O(68°F), inHg, ftH ₂ O, ftH ₂ O(68°F) or psi. (Only one unit can be specified)
Display setting	Designated differential pressure value specified in order. (% or user scaled value.) Display mode 'Linear' or 'Square root' is also as specified in order.
Static pressure display range	'0 to 25 MPa' for M and H capsule, absolute value. Measuring low pressure side.

T18E.EPS

- *1: To specify these items at factory, /**CA** or /**CB** option is required.
*2: Not available for HART protocol type.